

Ribbon Mic Details

1. Introduction

The introduction, in 1933, of pressure-gradient ribbon microphones into broadcast studios brought about a marked improvement in transmission quality. Not only was the response of these microphones more uniform at high frequencies than that of most pressure-type microphones of the period, but the directional properties—at least in the plane perpendicular to the length of the ribbon—varied only slightly with frequency, so that the reverberant as well as the directly received sound was more faithfully reproduced.

In spite of the advances in design of other types of microphone—notably the electrostatic variety—in the last two decades, the pressure-gradient ribbon microphone, by reason of its simple construction, low cost, and ease of maintenance, is still used for indoor work in this country in greater numbers than any other kind. The BBC-Marconi Type A microphone, believed to be the first of this type to be manufactured in Great Britain, was produced in 1934, and although a few improvements have subsequently been incorporated, the basic design remains unaltered. The performance of this microphone is still good, even by modern standards, but the instrument is bulky and there has long been a demand, arising in part from the special needs of the Television Service, for a smaller version giving an equal or better performance. In the absence of any commercial microphone capable of meeting this requirement, the BBC Research Department began in 1951 to develop a new design.

The existing BBC microphones were of two outwardly similar types, known as the AXB and AXBT; these had open-circuit sensitivities of -77 db and -71 db respectively relative to 1 volt/dyne/cm², with impedances of 300 ohms, the difference being due to the use of modern permanent magnet material in the later model. In laying down design requirements for a successor to these microphones, some doubt was felt regarding the best compromise between the conflicting requirements of high sensitivity and small size. It was found that some sixty per cent reduction in the volume occupied by the original microphone could be achieved while retaining the sensitivity of -71 db; but the question then arose whether some departure from this figure, which is well above the average for high-quality ribbon microphones, could be allowed in exchange for a further reduction in dimensions.

It was eventually decided to offer to the operational departments the choice of two designs, designated PGD and PGS (the final letter referring to the double-ended and single-ended magnet systems employed), having sensitivities of -71 db and -75 db respectively, with a corresponding difference in size. Prototypes underwent service trial during 1952 and the PGS design was selected as the better compromise between the various requirements.

Although the present monograph is mainly concerned with the type PGS microphone, reference will also be made throughout to the type PGD as an example of the alternatives open to the designer and as an illustration of some technical problems; a certain amount of information on the type AXBT is also given for comparison.

In the sections which follow, various parts of the microphone design are considered in detail, the effect of some of the variable factors shown, and an account given of the experimental methods used in the development. Finally, various aspects of the performance are discussed with reference to test data obtained on a number of production specimens.

2. Design Details

2.1 General

Fig. 1 shows the dimensions and weights, and Fig. 2, the general appearance, of the PGS and PGD microphones, an AXBT microphone being included for comparison.

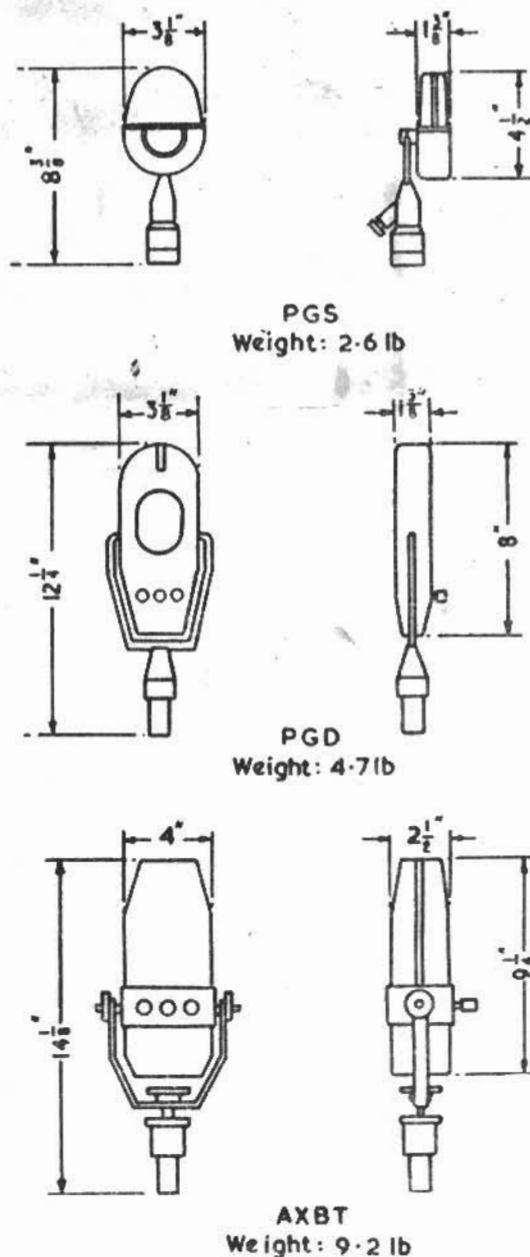
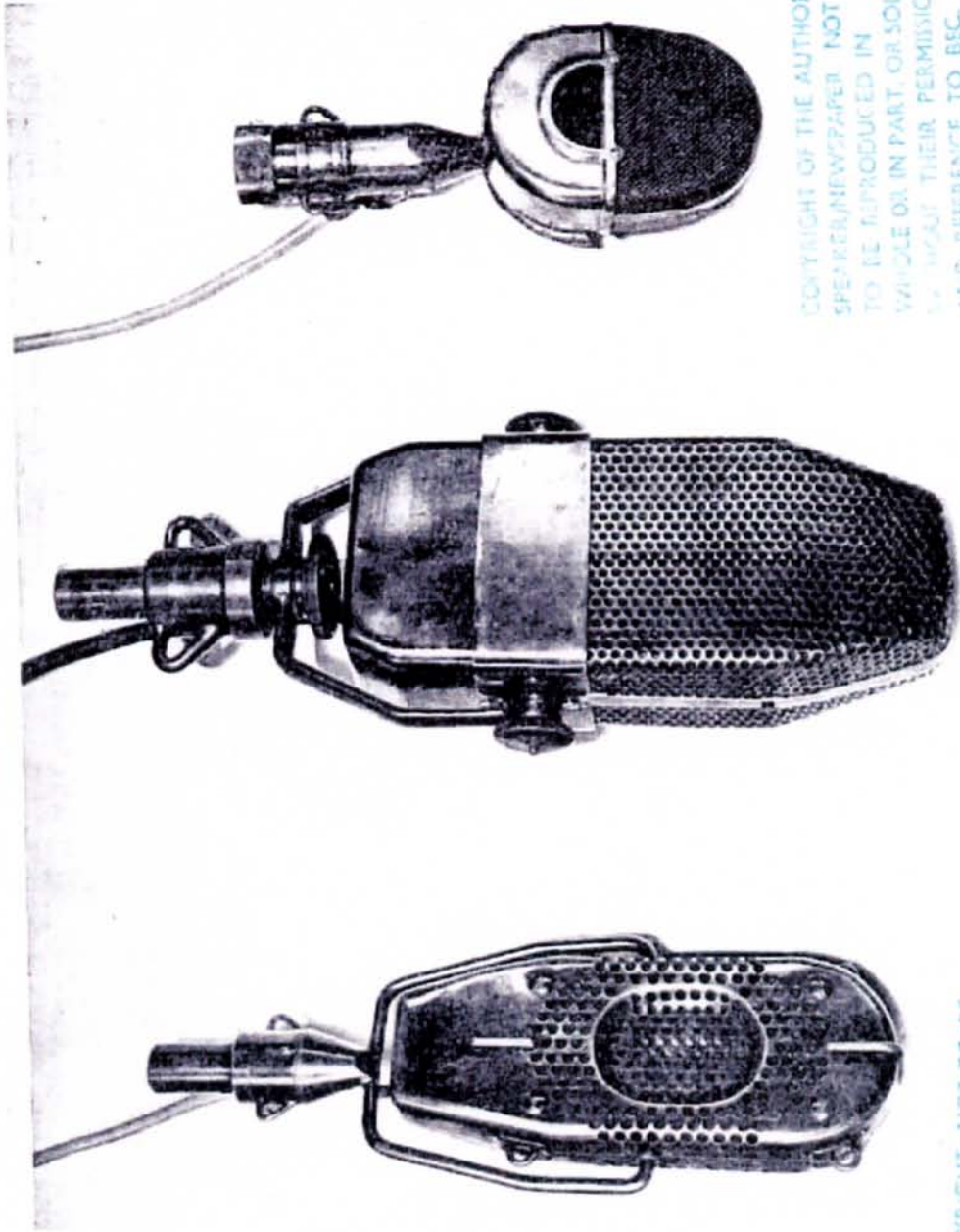

Fig. 1 — Dimensions and Weights of Microphones Type PGS, PGD, and AXBT

Because of the wide gap between the pole pieces the magnetic system of a ribbon microphone is very inefficient; only two to ten per cent of the flux leaving the permanent magnet appears at the pole tips. Before

Figs. 3 and 4 show the PGS microphone partially dismantled; with the exception of the magnet system and case, which will be dealt with later, the essential features of the PGD microphone are similar.



BEC COPYRIGHT. NOT TO BE REPRODUCED IN WHOLE OR IN PART, OR SOLD WITHOUT PERMISSION FROM THE B.C.

COPYRIGHT OF THE AUTHOR/
SPEAKER/NEWSPAPER NOT
TO BE REPRODUCED IN
WHOLE OR IN PART, OR SOLD
BY WHOLESALE WITHOUT THEIR PERMISSION
AND REFERENCE TO B.C.

Fig. 2 — Microphones Type PGD (left), AXBT, and PGS (right)

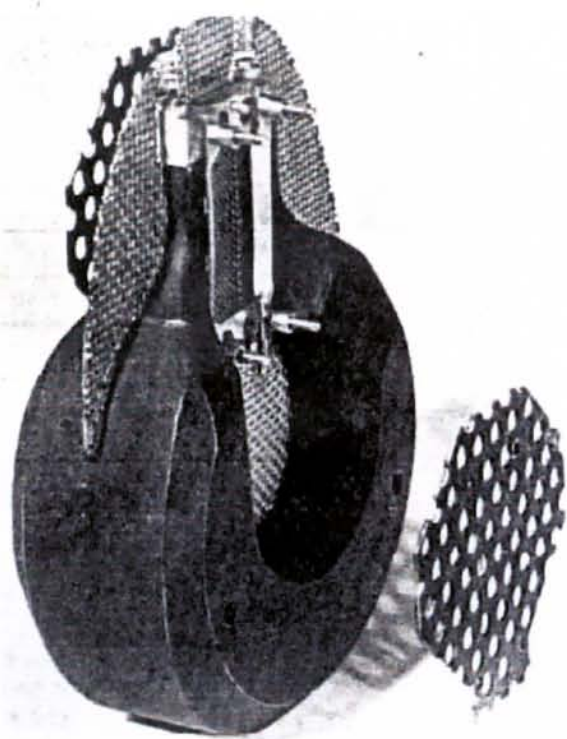

Fig. 3 — Microphone Type PGS. Magnet Assembly with ribbon carrier, damping screen, baffle, and reflectors

full size) representing one of the two pole pieces and a large conducting sheet representing the equipotential surface midway between them.

Fig. 5 shows the experimental arrangement in diagram-

plane, of which the small rectangular area *B*, immediately opposite the pole tip, is insulated from the remainder. The area *B* embraces the useful part of the field, in which the maximum possible flux is required; the ratio of the useful flux, thus defined, to the total flux is

$$\frac{C_{AB}}{C_{AB} + C_{AE}}$$

denote the capacitances from *A* to *B* and from *A* to *E* respectively. The values of C_{AB} and $C_{AB} + C_{AE}$ were directly determined by a transformer-ratio capacity bridge⁽²⁾ operating at a frequency of 10 kc/s and capable of measuring less than 0.001 $\mu\mu\text{F}$, the effect of the capacitances from *A* and *B* to *E* being automatically eliminated in the former case by connecting *E* to the neutral terminal of the bridge.

Experiments were carried out with the pole tips having various shapes and angles of chamfer and with the pole tips flat, radiused, and recessed. Fig. 6 shows typical data obtained by this method; in each case the percentage of flux crossing the central area is plotted as a function of gap width. Recessed poles show a slight advantage, particularly with narrow gaps, but leave too large a leakage space on either side of the ribbon. For the present purpose, the best shape, having regard to the necessary cross-sectional area of the pole, was found to be the straight chamfer with an angle of 60 deg. and flat pole-tip surfaces. For reasons to be discussed in the next section, the gap width was made 0.25 inch.

Concurrently with the work described above, the acoustic effect of various possible shapes of permanent magnet and pole piece was investigated by means of scale models built of wood and plasticine and fitted with ribbons; the models were approximately twice full size, the test frequencies being chosen in accordance with the appropriate scale factor. The magnetic field in the models was produced by small blocks of permanent magnet material

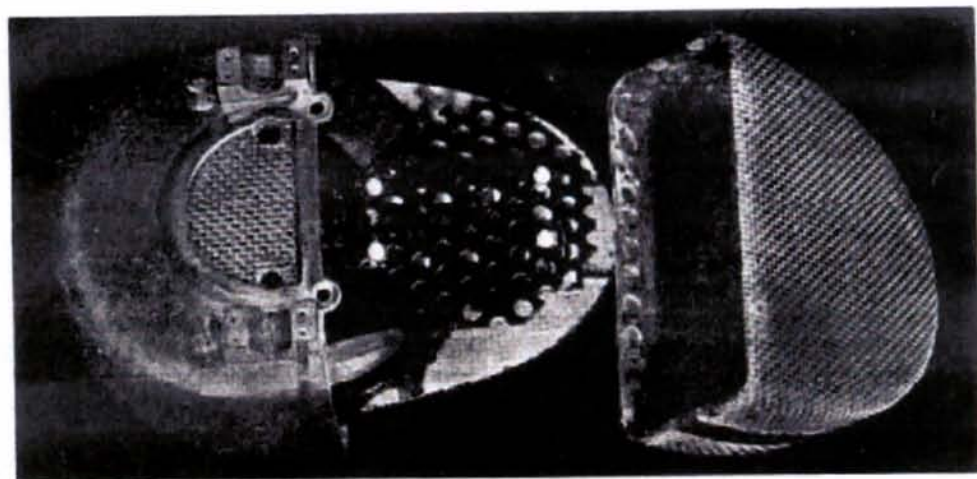

Fig. 4 — Microphone Type PGS. Assembly with stirrup removed

BBC COPYRIGHT NOT TO BE REPRODUCED IN WHOLE OR IN PART, OR SOLD WITHOUT PERMISSION FROM THE BBC.

BBC COPYRIGHT NOT TO BE REPRODUCED IN WHOLE OR IN PART, OR SOLD WITHOUT THEIR PERMISSION AND REFERENCE TO BBC.

let into the pole pieces and the resulting sensitivity, although low, was adequate for preliminary tests.

The acoustic effect of the pole pieces was not critically dependent on the shape and chamfer provided that the angle shown in Fig. 6 was greater than 45° and the form already arrived at from consideration of the magnetic systems was therefore adopted. On the other hand, the acoustic obstruction created by the permanent magnet and its junction with the pole-pieces produced some deterioration in frequency response and was the subject of much experiment. There are in effect two external paths between front and back of the ribbon, namely, the short distance round the pole pieces and the long distance round the magnet. The length of the latter path is such as to give a relatively high sensitivity combined with a corresponding low cut-off frequency; above this frequency there is a change of regime and the microphone response falls to a level which depends on the distance around the pole pieces. The effect is most clearly shown in the case of the PGD design, in which the two magnets are close together, by a step in the axial frequency characteristic at about 2000 c/s. By extending the magnet system so that the main bulk is kept further away from the pole pieces and ribbon, the size of the step can be reduced; the advantage thus obtained is partly offset however by the increase in leakage flux which makes it necessary to use a larger magnet to give the same useful flux. The final compromise involved to some extent the length of the ribbon, which in the case of the PGD microphone had to be made slightly longer than in the PGS to obtain acceptable characteristics.

The useful flux density in the PGS microphone is fairly constant over the length of the poles, but varies across the gap from 6500 gauss at the pole tips, to 4500 gauss at the

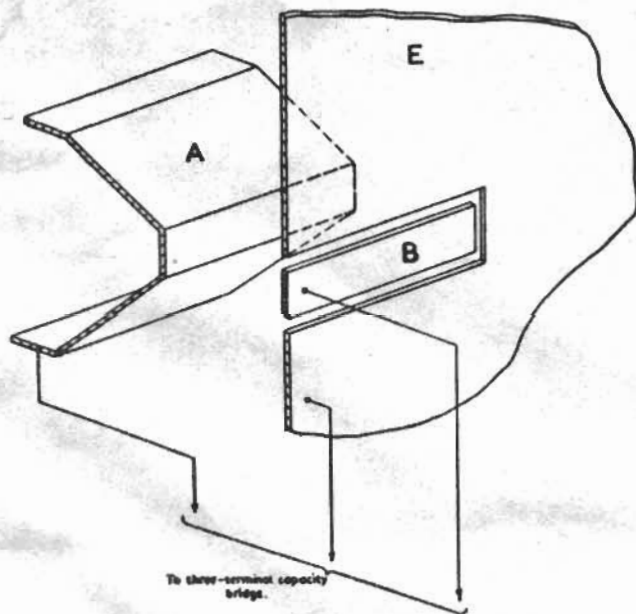

Fig. 5 — Microphone Type PGS. Section of Electrostatic model used for determination of Magnetic Leakage (Simplified Diagram)

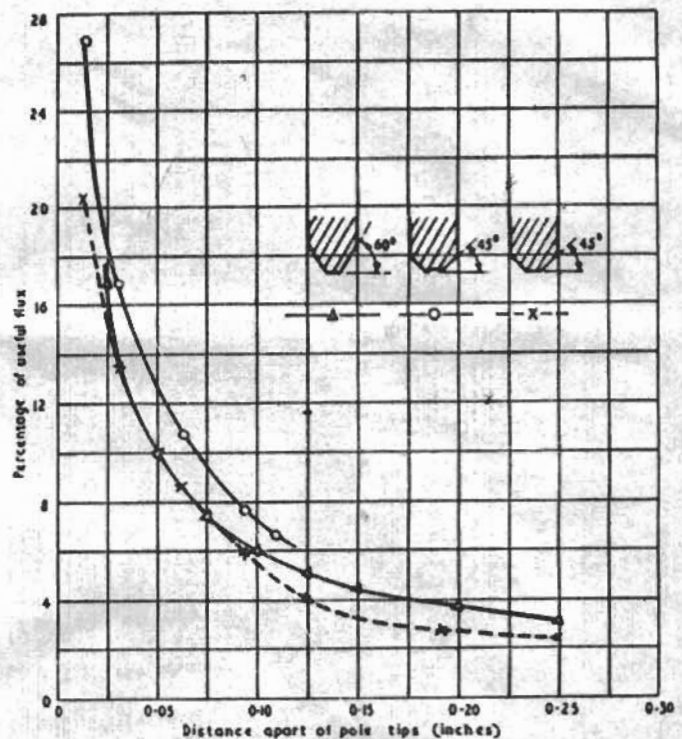

Fig. 6 — Microphone Type PGS. Ratio of useful flux to total flux between pole pieces. Data obtained by electrostatic model

centre. The flux density in the mild steel pole pieces is not high and only about five per cent increase in the gap flux can be obtained by the substitution of materials such as Permendur, having a relatively high magnetic saturation point. For the purpose of the present design, this small advantage was not considered sufficient to outweigh the manufacturing difficulties associated with the alternative pole materials; in large-scale production, however, using pole pieces produced by the method of investment casting, the increase in efficiency obtained might prove worth while, if only because it would permit the specification for the permanent magnet to be slightly relaxed.

2.3 Ribbon

2.3.1 Length

The upper limit to the length of the ribbon is decided by the allowable high-frequency loss which occurs when the source of sound lies off the microphone axis in the vertical* plane; the lower limit is set by considerations of sensitivity, by the acoustic obstacle effect of the magnet system, and, ultimately, by the necessity of keeping the fundamental resonance frequency low. In the PGS microphone, a compromise has been reached with a ribbon length of 1 in.; in the PGD design, for reasons explained in Section 2.2 this figure was increased to 1.125 in.

* Throughout this text the terms 'horizontal', 'vertical', 'above', and 'below', when used to describe the angle of incidence of the sound, have the sense indicated by the diagrams in Figs. 16 to 21.

2.3.2 Width

The width of the ribbon is determined by a number of opposing factors; for example, a wider ribbon has a lower electrical resistance but with a wider gap the magnet sys-

depart somewhat from the conditions for optimum efficiency for the sake of greater smoothness of frequency response. In addition to its fundamental longitudinal resonance mode, which is commonly arranged to occur at

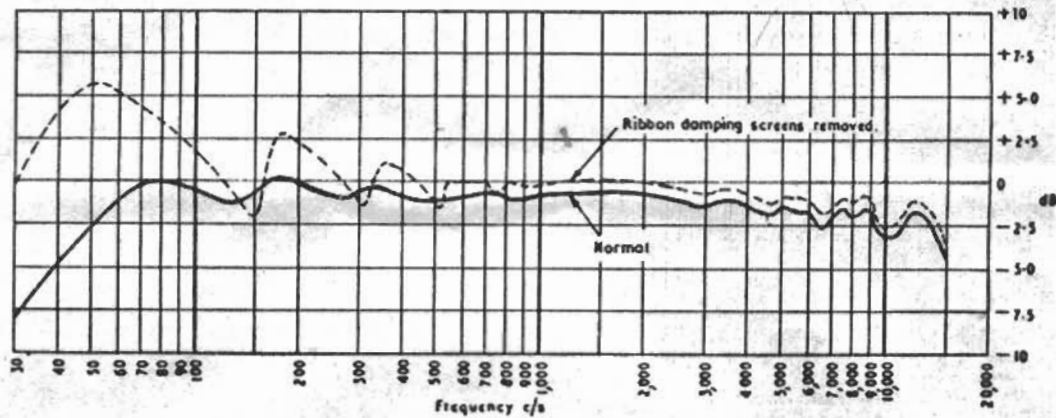

Fig. 7 — Microphone Type PGS. Open-circuit axial frequency response with and without ribbon damping screens

tem is less efficient. The open-circuit sensitivity of a ribbon microphone having a given output impedance at the secondary winding of the ribbon/line transformer varies only slowly with ribbon width; considered from this point of view, the optimum width for an undamped ribbon is usually of the order of 0.1 in. to 0.2 in., the exact figure depending on the clearance allowed between ribbon and poles and the degree of magnetic saturation of the pole tips. It is not always convenient, however, to operate the microphone into open circuit and it is necessary to consider the effect of a resistive load. In a high-efficiency microphone, the motional impedance of the ribbon at low frequencies may be comparable with, or even exceed, its static resistance. The imposition of an external resistive load will therefore cause the frequency characteristics to fall at the bass, and it can readily be shown that for a given sensitivity this effect becomes more pronounced as the area of the ribbon is reduced. Moreover, for reasons which will be considered later, it is necessary in the PGS microphone to apply acoustic damping to the ribbon. The effectiveness of the damping is somewhat reduced by the leakage of air through the inevitable space between ribbon and poles and to minimize this effect, the width of the ribbon should be large compared with the width of the space. Consideration of these additional factors led, after some experiment, to the choice of a ribbon 0.23 in. wide working in a 0.25 in. wide gap.

2.3.3 Material and Thickness

To give maximum efficiency the material used for the ribbon should combine low resistivity with low density and for this purpose there is still no practical alternative to aluminium.

For any given pole structure, there is an optimum ribbon mass which will match the acoustic reactance load imposed by the air. It is sometimes necessary however to

or below the lowest frequency of interest, a microphone ribbon possesses a number of modes of higher order; these may appear as a series of kinks in the frequency response curves and, unless well damped, their effects are audible as a slight blurring of the reproduced sound. Ribbons of thick, springy material are the worst in this respect and much smoother frequency response curves are obtained with thin beaten aluminium leaf, which has an appreciable amount of internal damping. Material of this kind 2.5×10^{-8} in. (0.6 micron) thick and weighing 0.2 mg/cm² has been used for many years in the type A microphone and is again employed in the PGS design. Although the mass is slightly less than the optimum referred to above, the loss in efficiency due to this cause is less than $\frac{1}{2}$ db.

The d.c. resistance of the ribbon in the PGS microphone is 0.22 ohm.

2.3.4 Acoustic Damping

In practice, the shorter the ribbon, the more prominent are its resonances and with the reduction in length from 2.7 in. in the type A to 1 in. in the PGS, some external damping was found necessary to preserve a sufficiently smooth frequency response. The required effect is achieved acoustically by screens of wire gauze at the front and back of the ribbon; one of these screens can be seen in Fig. 3 while Fig. 7 shows the effect on the microphone response. The screens are of Monel metal and, being slightly magnetic, are held in place by the attraction to the pole pieces; they also serve as a trap for any magnetic particles which may find their way into the case. When a ribbon is vibrating in one of its higher modes, there is an alternating air flow between adjacent sections vibrating in antiphase. For effective damping of these modes it is essential that a large part of this flow should pass through the wire gauze screen which must therefore be placed as close to the ribbon as is

consistent with the required freedom of movement; in the PGS microphone the spacing is 0.03 inch.

To damp the higher modes of the ribbon, the effective mechanical resistance introduced by the screens has to be comparable with the mass reactance of the ribbon at low frequencies and thus introduces a bass loss as shown in Fig. 7; this loss is compensated, however, by a device which will be dealt with in a later section.

2.3.5 Tension

To minimize the effect of longitudinal resonance, the ribbon tension should be kept as small as possible; since, however, a lightly tensioned ribbon is easily moved by draughts and structure-borne vibration, some compromise has to be effected. With the damping arrangements described above, the tension, and hence the fundamental resonance frequency, of the PGS ribbon may be varied over a fairly wide range without seriously affecting the response of the microphone in the working frequency band. Thus, the fundamental resonance frequency of the unloaded ribbon can be made as low as 25 c/s without risk of mechanical instability or of excessive sagging when the microphone is used in a horizontal position. If, on the other hand, the ribbon tension is increased until the fundamental resonance occurs at 45 c/s, the low-frequency response characteristics do not deviate by more than $\pm \frac{1}{2}$ db from a smooth curve while the transient response, investigated by driving the ribbon electrically with interrupted tone and observing on an oscilloscope the voltage generated during the 'off' periods, remains substantially aperiodic. To minimize the effects of wind and vibration, the resonance frequency is therefore kept near the higher figure.

are subjected in service. In the course of the investigation attempts were made to simulate this aspect of service conditions by such expedients as passing a.c. of square waveform through the ribbon to produce abnormally large deflections; these methods however gave grossly over-optimistic results, and impact tests were found to be essential. As a result of these experiments, the ribbon in the final design was formed with twenty corrugations per inch but these corrugations were pulled nearly flat on fitting; with this arrangement, sagging of the ribbon is prevented, while the production variation in high-frequency response is held within about $\pm \frac{1}{2}$ db.

Fig. 8 shows the effect of ribbon corrugation on high-frequency response in a few typical cases. For the sake of clarity, only differences in frequency response are shown, the datum line (a) being the response of a microphone having a ribbon so deeply corrugated that the first transverse resonance mode lay above 20 kc/s. Curve (b) shows the effect of transverse resonance within the working band, a result which could in some circumstances, be turned to good account if the ribbon could be made sufficiently stable. Curve (c) relates to a typical PGS microphone.

2.3.7 Motional Impedance Measurements

Most of the design information on the effect of changes in ribbon thickness, tension, and type of corrugation was obtained by motional impedance measurements. For this purpose, the microphone under test was divested of its case, low-frequency baffles, high-frequency reflector plates, and damping screens. The ribbon, which may be represented as a motional impedance Z_m in series with a blocked impedance Z_1 , was connected in one arm of the bridge circuit shown in Fig. 9, an impedance Z_2 , approximately

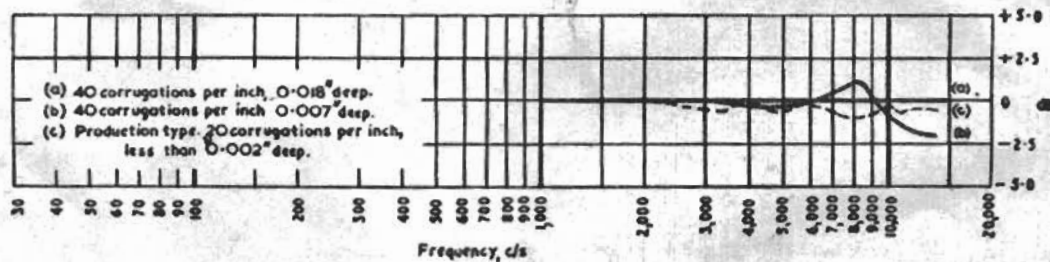

Fig. 8 — Microphone Type PGS. Change in high-frequency response with form of ribbon corrugation

2.3.6 Corrugations

At the higher frequencies—in the present instance, above about 3 kc/s—the response of the microphone is affected to some degree by transverse resonance modes of the ribbon; the extent to which these modes are excited depends partly on the degree of accidental asymmetry of the ribbon, and the result is therefore not always under control. Consistent performance can be achieved by using corrugations of fine pitch, but such corrugations were found to straighten out after a time as a result of the mechanical vibrations and shock to which microphones

equal to Z_1 , being provided in the adjacent arm. With the ribbon temporarily immobilized by immersion in a bath of liquid (a volatile substance being employed to hasten the subsequent drying) and Z_m thus removed, the bridge was balanced by adjustment of the resistor R_1 and of a small capacitor C_1 connected in parallel with either R_1 or R_2 as required. The bath of liquid was then removed, the ribbon allowed to dry, and the unbalance voltage from the bridge recorded, as a function of frequency, by conventional curve-tracing equipment. R_1 , R_2 , and the impedance of the bridge output circuit are made high compared with Z_1 and

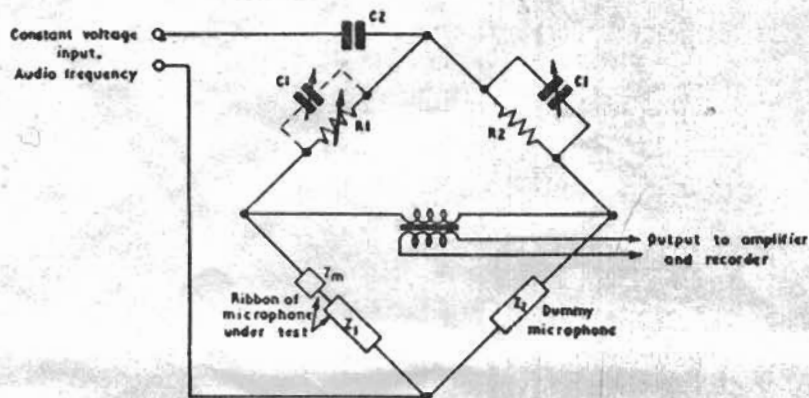

Fig. 9 — Motional impedance bridge circuit

Z_1 ; the quantity recorded was therefore proportional to Z_m , i.e. to the voltage generated by the ribbon in response to a given current. To a first approximation, the force produced by this current can be regarded as replacing the force which would be produced by a certain sound field. The force due to the sound field will be proportional to frequency as long as the microphone is small compared with a wavelength. In so far as this requirement is met, the output from the motional impedance bridge can be made proportional to the response of the microphone to sound by making the current passing through Z_1 likewise proportional to frequency; the required effect is achieved in the circuit of Fig. 9 by the provision of a series capacitor C_2 , the reactance of which, up to the highest frequency of interest, is large compared with the input impedance of the bridge.

Fig. 10 shows a typical example of a characteristic obtained with a particular experimental ribbon using the circuit of Fig. 6; the initial balancing operation was carried

out at 10 kc/s. In the absence of the damping screens, the longitudinal resonance modes of the ribbon are very prominent at frequencies below 1000 c/s; in this frequency range, the acoustic response of the microphone followed closely the curve of Fig. 10. The two peaks at approximately 10 kc/s and 11 kc/s are associated with transverse resonance modes of the ribbon; because of the non-uniformity of the magnetic field, which is about thirty per cent weaker in the centre of the ribbon than at the edges, these modes are more strongly excited when the ribbon is driven electrically than they would be under normal working conditions and the change in motional impedance which they produce is greater than the corresponding change in acoustic response.

The 'response' curves obtained from the motional impedance bridge differ from the corresponding acoustic response curve not only because they do not show the effects which occur at high frequencies, when the wavelength of sound is comparable with the dimensions of the

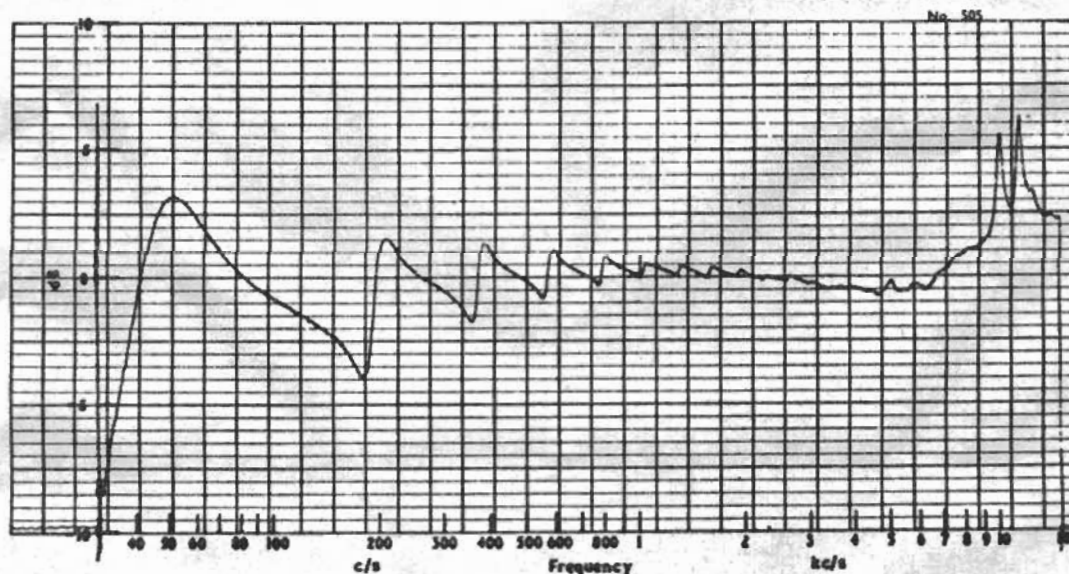

Fig. 10 — Example of curve taken with experimental ribbon using motional impedance bridge

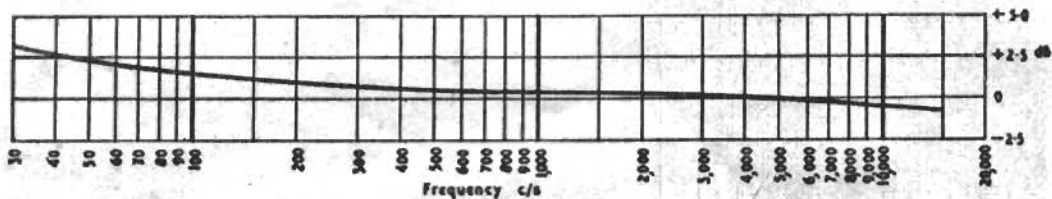

Fig. 11 — Microphone Type PGS. Change in response produced by low-frequency baffles

microphone, but also because the natural distribution of driving force over the ribbon may not always be exactly reproduced. The information displayed was nevertheless of great value in the detailed investigation of ribbon behaviour, since small irregularities in the motional impedance frequency characteristic could be delineated with an accuracy and speed not readily attained in acoustic measurements. The motional impedance measurement was moreover independent in practice of the acoustics of the environment and it was found that the whole operation could be carried out in a live room in the presence of a considerable amount of ambient noise.

The technique described, while simple in principle, calls for some refinement in instrumentation, for though at 50 c/s the motional impedance of the ribbon may be of the same order as its blocked impedance, its value at 10 kc/s is likely to be about half per cent of this, i.e. of the order of 10^{-3} ohm. The initial bridge balance must therefore be accurately maintained over the frequency range and to this end the effect of the ribbon inductance which, because of the proximity of the magnet pole pieces, varies slightly with frequency, has to be taken into account. The impedance Z_1 therefore takes the form of a dummy microphone in which the ribbon is replaced by a strip of copper foil, the resistance being brought up to the normal value by a short length of Eureka wire included in the external connections; the copper foil and the Eureka wire are embedded in plasticine to prevent vibration.

Given these precautions, the method of operation is quite straight-forward and a curve such as that of Fig. 10 can be obtained in a few minutes.

2.4 Low-frequency Baffle

The low-frequency loss caused by the heavy damping of the ribbon is compensated by surrounding the ribbon by a

baffle of closely woven gauze. This device was first used by von Braunmühl and Weber⁽³⁾ in electrostatic microphones and later applied to ribbon microphones by Olson⁽⁴⁾. Its action depends on the fact that the acoustic impedance of the external path between front and back of the diaphragm increases with frequency, so that a porous baffle having a fixed impedance so low that its influence is negligible at high frequencies can act as an obstacle at lower frequencies. In this way, the effective length of the front-to-back path, and hence the phase difference between the pressures acting on the two faces of the diaphragm (in the present instance, a ribbon) becomes relatively greater at low frequencies and the bass response is correspondingly increased. The frequency range over which the change of regime described takes place depends on the acoustic impedance of the baffle, which in the PGS microphone consists of a single layer of bolting cloth supported by a coarse wire mesh, disposed, as shown in Fig. 3, on either side of the ribbon and in the hollow of the permanent magnet. Fig. 11 shows the change in the response of a PGS microphone produced when the baffle is added. The baffle must be a close fit on the magnet and poles; a gap of 0.06 in. is sufficient to reduce the effect shown in Fig. 11 to one-half.

2.5 Case and High-frequency Reflectors

The outer case of a microphone has in general an important influence on the characteristics, for a structure which is robust enough to withstand handling and offers sufficient resistance to air-flow to exclude draughts and dust is likely to present an appreciable obstacle to sound. In the present instance the principal effect of the case on the performance of the microphone occurs at high frequencies, at which reflection of sound takes place between the inner surfaces in front of and behind the ribbon. Such

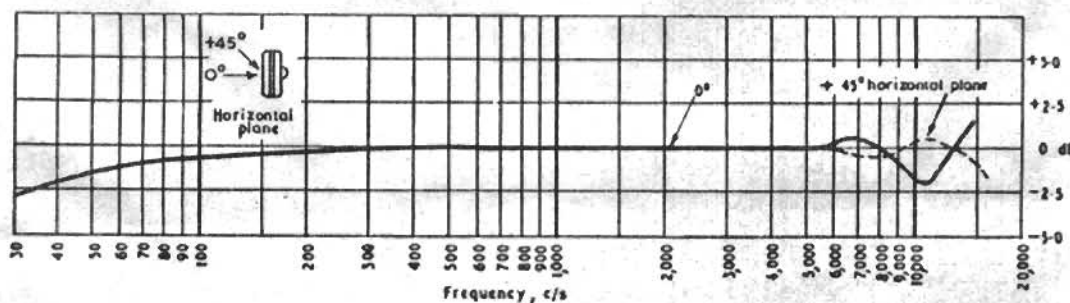

Fig. 12 — Microphone Type PGS. Change in response produced by case

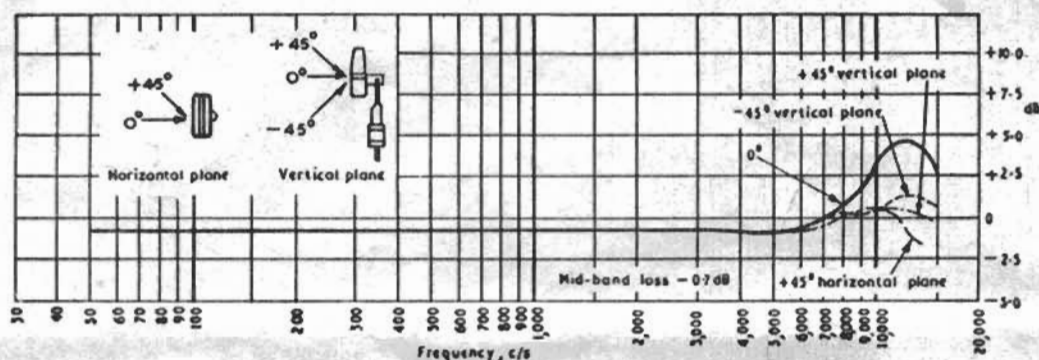

Fig. 13 — Microphone Type PGS. Change in response produced by high-frequency reflectors

reflections modify the sound field in the neighbourhood of the ribbon, increasing the response of the microphone at some frequencies while reducing it at others. Thus, unless special care is taken in the design of the case, the result may be detrimental to the overall performance. The degree of obstruction presented by the microphone case to sound at high frequencies increases not only with the proportion of the total area obstructed but to a large extent with the thickness of the material. For example, perforated metal produces a greater change in high-frequency response than does fine wire mesh while with bars or grilles, even if narrow and widely spaced, the effects are even more pronounced.

In the PGS microphone, the removable upper part of the case, which surrounds the ribbon, is constructed of perforated brass over which are stretched two layers of wire gauze, the inner fine and the outer coarse. To minimize the effects of internal reflections, the perforated brass, which at high frequencies constitutes the principal obstruction to sound, is cut away to form D-shaped windows in front of and behind the ribbon. The influence of the upper part of the case on the microphone response is shown in Fig. 12; it will be seen that there are still some signs of internal reflection above 6 kc/s. Fig. 12 also shows a slight loss at low frequencies. A small part of this loss is accounted for by the increased resistive air loading imposed on the ribbon by the wire gauze but the effect is mainly due to modification, by the cover, of the sound field acting on the ribbon.

The results of reflection at high frequencies by obstacles near the ribbon can sometimes be turned to good account by appropriate spacing of the surfaces concerned. This artifice is employed in the PGS microphone by mounting, in front of and behind the ribbon, parallel reflectors of perforated plastic material, shown in Figs. 3 and 4. The influence of these reflectors on the response of the microphone can be seen from Fig. 13. The standing loss of 0.7 db, due to the slight increase in the reactive load imposed by the air on the ribbon, is more than offset by a useful rise in axial response up to about 13 kc/s. The effect is similar in kind to that shown in Fig. 12 but because the distance between reflectors is less than the depth of the case, the maxima and minima in the curve occur at higher fre-

quencies. The amount of the rise in response, which is controlled by the thickness of the reflectors and the fraction of their area occupied by perforations, has been arranged as far as possible to offset the natural fall in response which occurs in a pressure-gradient microphone at high frequencies when the wavelength of the sound is no longer large compared with the effective pathlength between the front and back of the moving element. Because the perforated plates have dimensions comparable with a wavelength in their operative frequency band and in addition give only partial reflection, the frequencies of the maxima and minima in response which they produce are not simply related to the spacing between them. In the present instance, the frequency of the first maximum shown in Fig. 13 was found to vary, over the range of interest, inversely as the cube of the spacing. It will be seen from Fig. 13 that the effect of the reflectors is less for sound arriving at an angle to the axis; in this case, however, the fall in response which it is desired to correct is also less, so that the presence of the reflectors also reduces the variation in overall frequency response with angle of incidence.

It may be of interest to note that perforated plates similar to those described but covered with thin cloth were provided in some of the earliest pressure-gradient ribbon microphones as puff-shields, though the thickness of material used and the spacing were such that any fortuitous effect on the high-frequency response must have been small. The use of such reflectors for the purpose of improving the performance of the microphone at high frequency in the manner described above was however described independently by Olson in a patent disclosed in October 1951⁽⁴⁾.

In the interests of mechanical rigidity, a different form of case construction is adopted for the double-ended microphone PGD. Here, the effects which in the PGS microphone are produced by internal reflector plates are achieved by dishing the perforated case at front and back as shown in Fig. 2, so that the surfaces opposed to the ribbon are separated by the optimum distance. The same device⁽⁴⁾ is, of course, applicable to a single-ended magnet structure and an example of this will be given in the appendix.

Because the magnet assembly of the PGD microphone

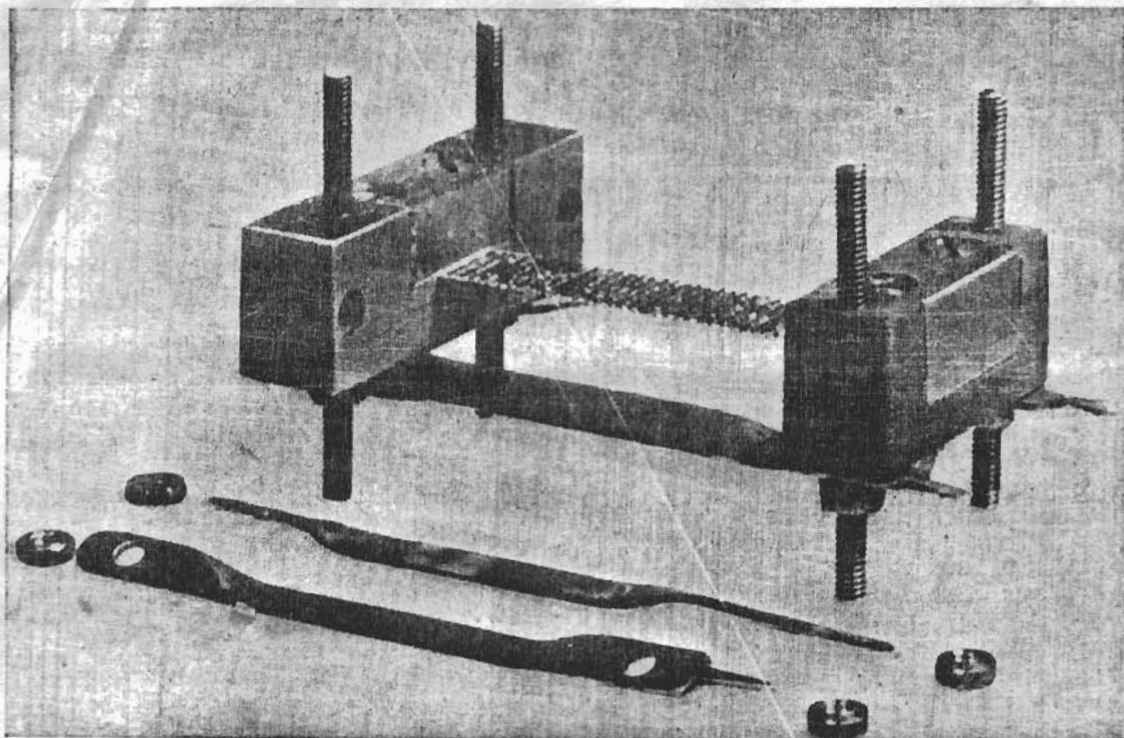

Fig. 14 — Microphone Type PGS. Ribbon carrier with ribbon

is completely symmetrical about both horizontal and vertical planes, and the outer case nearly so, the frequency characteristics for sound approaching from above and below the axis are generally similar. The same result cannot naturally be obtained with the single-ended magnet system of the PGS, but here, the degree of asymmetry is to some extent reduced at high frequencies by providing an auxiliary reflector⁽¹⁾ (not visible in Fig. 4) in the form of a plate approximately 2 in. \times 0.75 in. curved to fit inside the top of the perforated brass cover.

In the PGS microphone, the dimensions of the case are kept to a minimum by mounting the ribbon-to-line transformer in the base of the stirrup; the arms of the stirrup are made hollow and carry the connections from the ribbon. To minimize the overall width of the assembly, the stirrup, instead of embracing the case, is attached to one face; although the axis of rotation does not pass through the centre of gravity of the magnet system, the friction in the bearings is made sufficient to retain the microphone at any angle to which it may be set.

To enable the microphone to be slung in various positions, three suspension lugs are provided; these are carried on a rotatable ring encircling the stem; since the centre of gravity of the microphone is not in line with the stem, two of the lugs are asymmetrically placed so that the microphone can be made to hang vertically.

2.6 Output Connections

In bringing out the electrical connections from the ribbon to the primary winding of the ribbon-to-line trans-

former, special precautions are necessary to minimize induction pick-up from stray alternating magnetic fields. Interference of this kind has at various times been caused by heavy-current supply circuits, especially those containing rectifiers, by d.c. traction circuits carrying commutator ripple, and by the scanning coils of television equipment. Since 1943, ribbon microphones in the BBC have been internally wired in such a way as to form a pair of magnetically balanced loops in the ribbon circuit, a fine adjustment of the balance being effected by subjecting each microphone to a strong 1000 c/s magnetic field and slightly bending the wiring to give minimum pick-up. By this means a reduction in interference of more than 30 db has been achieved. In the new microphone the same result is obtained without the need for any trimming adjustment. The ribbon is mounted in a removable carrier, shown in Fig. 14. Electrical connection to one end of the ribbon is made through four brass straps joined in parallel and symmetrically disposed so that the effects of external magnetic fields are balanced out.⁽¹⁾ These straps are shaped to fit the chamfered faces of the magnet poles and thus serve to locate the ribbon in the gap; the poles are coated with an insulating varnish to prevent electrical contact with the straps. The ribbon carrier can be withdrawn for maintenance purpose by unsoldering the electrical connections and removing two of the straps as shown in Fig. 14.

Connection between the ribbon carrier and the transformer primary winding is made by two parallel-connected twisted pairs, one in each side of the hollow stirrup. Tilting the microphone head causes the ribbon connections to

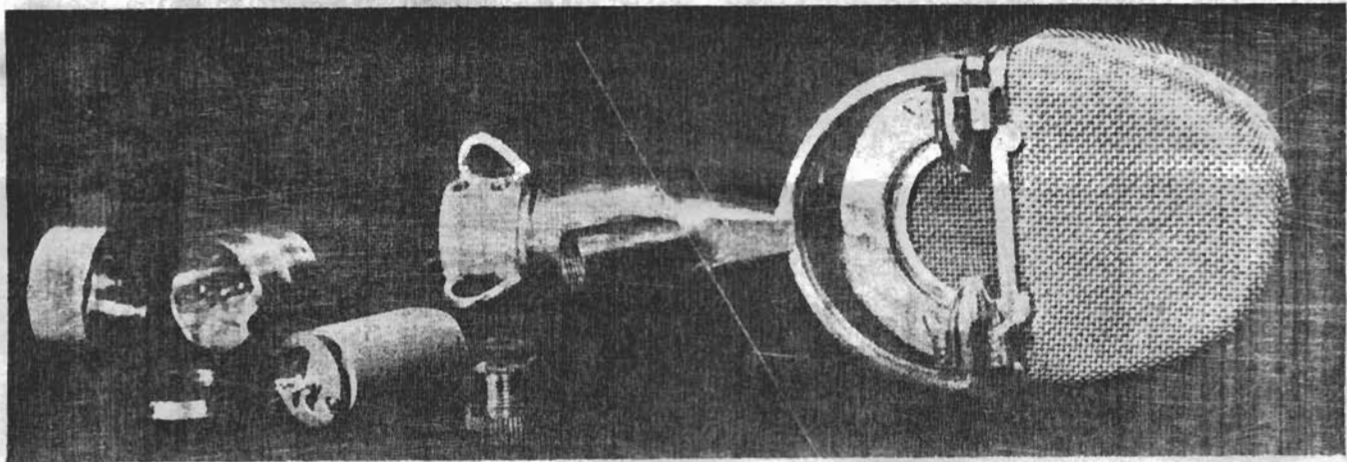

Fig. 15 — Microphone Type PGS. Rear view, base of stirrup dismantled

twist or untwist slightly; the maximum angle of tilt required is only 90 deg. so that the strain imposed on the conductors is small. The output from the transformer secondary winding is taken through a 0.25 in. diameter twin screened cable, the conductors of which are soldered to tags on the transformer. Fig. 15 shows the transformer, which has a Mumetal screen, removed from the microphone; details of the cable entry and cable grip can also be seen.

2.7 Protection against Vibration

Pressure-gradient microphones, particularly those having a good low-frequency response, are particularly liable to pick up structure-borne vibration. With light-weight instruments of this type, the degree of compliance in the mounting required to give protection in all circumstances against this form of interference is greater than can be conveniently obtained by internal shock-absorbers of practicable size. Rather than increase the dimensions of the new microphones by incorporating anti-vibration devices which would in some circumstances be superfluous and in others inadequate, it was decided to rely on the external mounting to give the required protection, a practice already followed in a number of commercial designs. With suspended microphones, adequate isolation can generally be obtained by the use of rubber thongs of appropriate thickness, but with a floor stand, some form of shock absorber is required and an anti-vibration mounting (not shown in the photographs) was therefore provided as a separate unit.

3. Performance

3.1 General

The following data on the performance of the PGS microphone were obtained from production models. Some corresponding data for the PGD type and for an AXBT microphone are given for comparison.

3.2 Frequency Response Characteristics

Figs. 16, 17, and 18 show the open-circuit frequency response characteristics of a typical PGS microphone for various angles of incidence in both horizontal and vertical planes. These curves refer to the response in a plane wave and do not include the bass rise which occurs when a pressure-gradient microphone is used in close proximity to a source of sound.

To show more clearly the variation in frequency response with angle of incidence and to facilitate comparison with the characteristics of other microphones, the curves for axial and 60 deg. incidence have been replotted together in Fig. 19. For 60 deg. incidence, the response of an ideal pressure-gradient microphone would be 6 db below the axial value; for comparative purposes, the 60 deg. curves in Fig. 19 are raised by this amount so that they coincide with the axial curves wherever the polar characteristic follows the ideal cosine law.

The angle of 60 deg. is chosen as embracing the most extreme conditions of use and in comparing Figs. 16 to 19 with published data on other types of ribbon microphone, it should be borne in mind that the worst frequency characteristics, which are those for sound sources above and below the axis, are seldom given in the literature.

The curves of Figs. 20 and 21 are plotted in the same way as those of Fig. 19 and refer to the PGD and AXBT microphones respectively. In all three figures the change in frequency response produced by loading the microphone with a resistance equal to its nominal impedance is also shown.

It will be seen that the high-frequency response of the PGS and PGD microphones is very much better than that of the AXBT, especially for sound incident obliquely in the vertical planes. Because of the relatively small obstruction presented by the single magnet system, the extreme high-frequency response of the PGS microphone is higher than that of the PGD, though the asymmetry of the vertical plane characteristics in the 2000 c/s-5000 c/s region is more apparent. The crevasse in the + 60 deg. curve of the

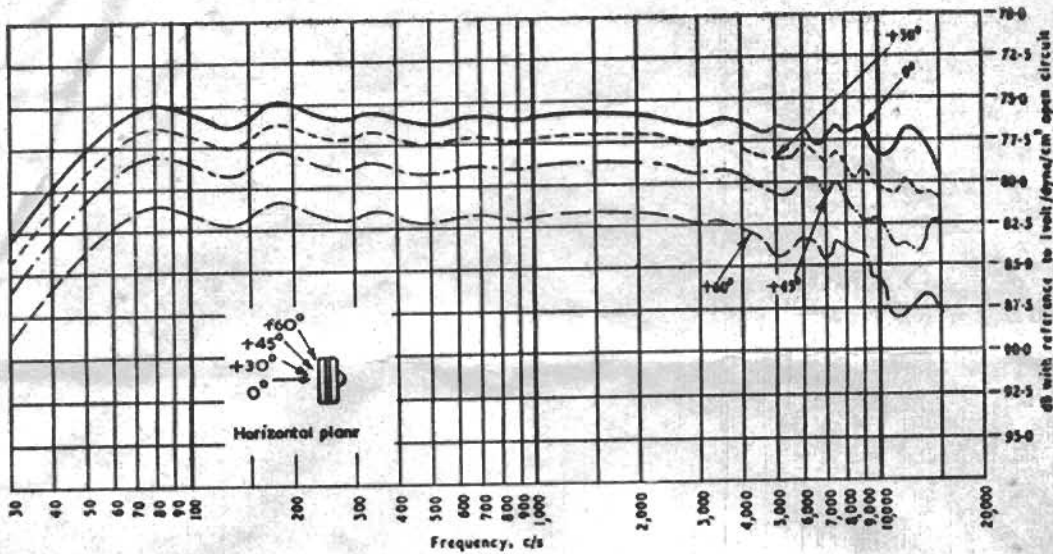

Fig. 16 — Microphone Type PGS. Open-circuit frequency response in horizontal plane

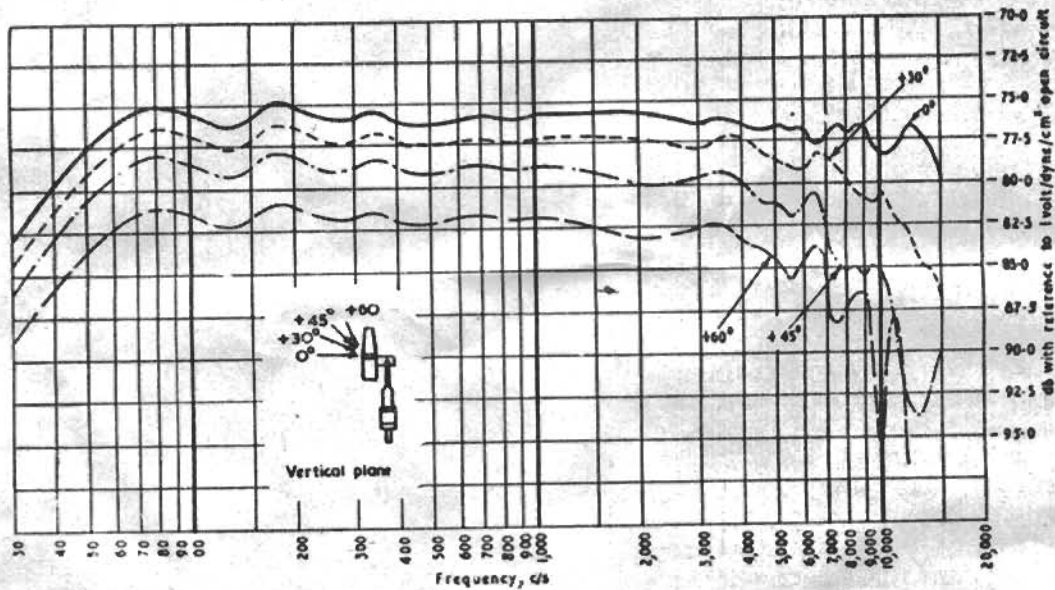

Fig. 17 — Microphone Type PGS. Open-circuit frequency response in vertical plane above axis

PGS microphone at 10 kc/s is due to interference; it will be noted that similar effects occur in the corresponding AXBT characteristics at lower frequencies.

The on-load frequency response of all three microphones below 500 c/s is generally similar, though the PGD, on account of its higher electromechanical efficiency, is affected to a greater extent than the others by the external electrical load. As already explained in Section 2.2 the PGD and PGS microphones are being operated with a relatively high ribbon tension, corresponding to a funda-

mental resonance frequency of over 40 c/s; it will be seen, however, that the damping provided is sufficient to keep the irregularities in frequency response in the neighbourhood of the higher modes within narrow limits.

Fig. 22 shows the variation in open-circuit axial frequency characteristic between individual PGS microphones; the data was obtained from tests on five production models. Below 1000 c/s, the spread is mainly due to differences in the ribbon tension and hence in the frequencies of the longitudinal resonance modes; at higher

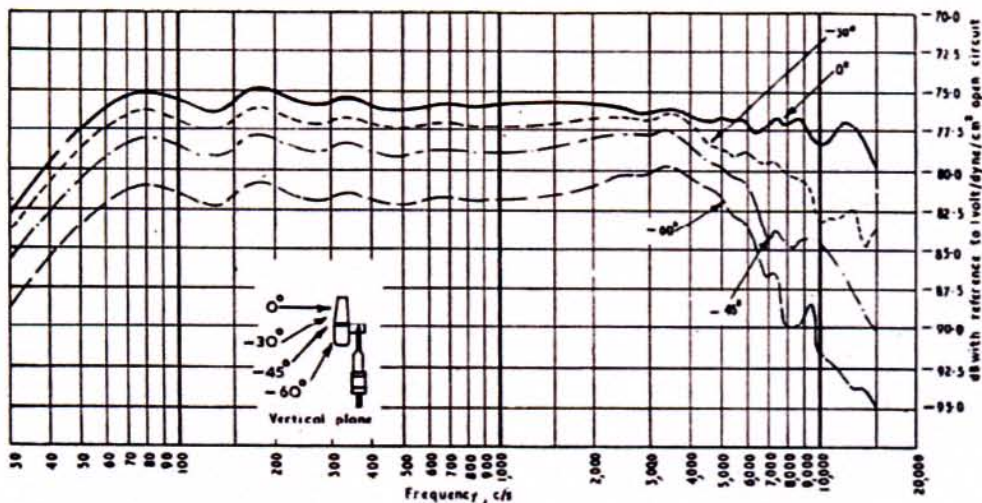

Fig. 18 — Microphone Type PGS. Open-circuit frequency response in vertical plane below axis

frequencies, variations arise from differences in ribbon material and depth of corrugation, which affect the transverse modes.

3.3 Sensitivity

The mean open-circuit sensitivity of the first 50 PGS

microphones produced was -75 db with reference to 1 volt/dyne/cm^2 . About three-quarters of these specimens had sensitivities within $\pm \frac{1}{2}$ db of the mean while the figures for the remainder lay within ± 1 db. Most of the spread was accounted for by differences in magnetic flux density in the gap.

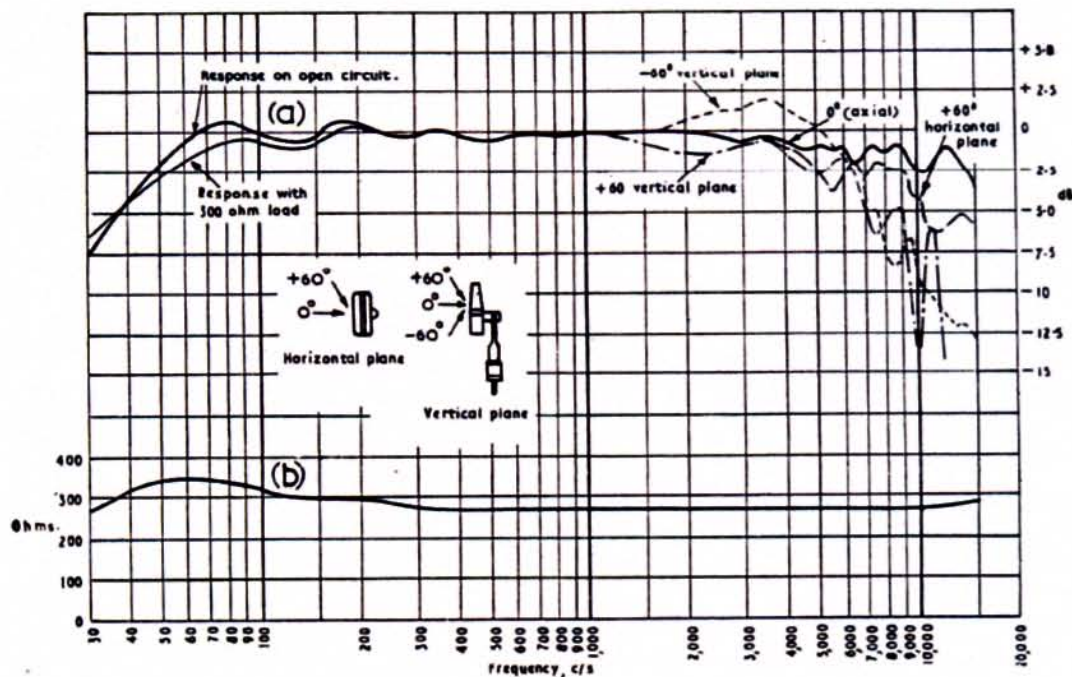

Fig. 19 — Microphone Type PGS

- (a) Variation of response relative to mid-band value with angle of incidence and with electrical load
 (b) Modulus of output impedance

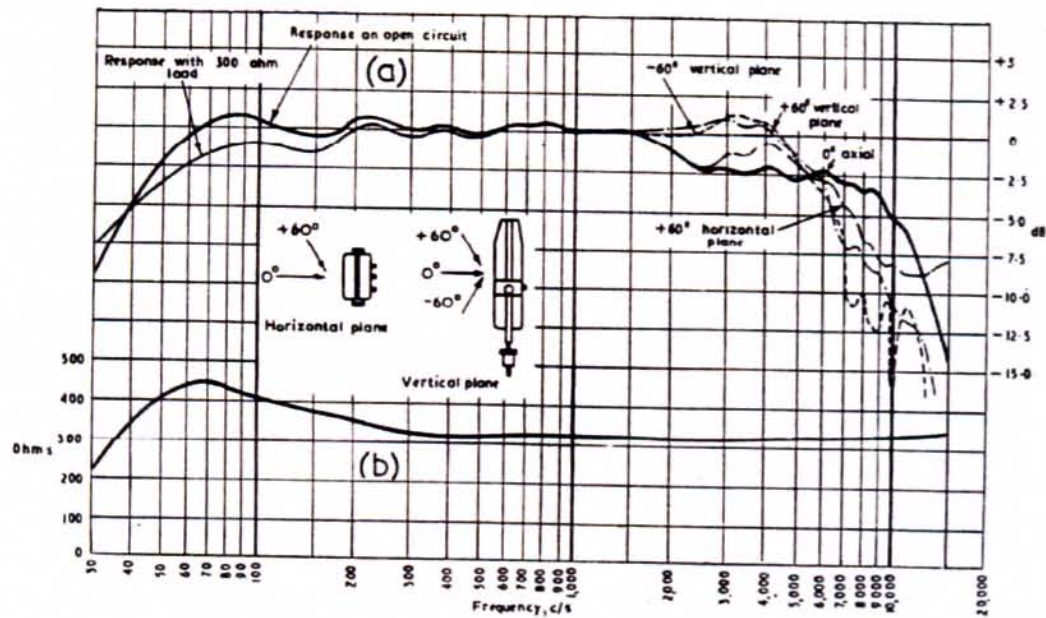

Fig. 20 — Microphone Type PGD

- (a) Variation in response relative to mid-band value with angle of incidence and with electrical load
 (b) Modulus of output impedance

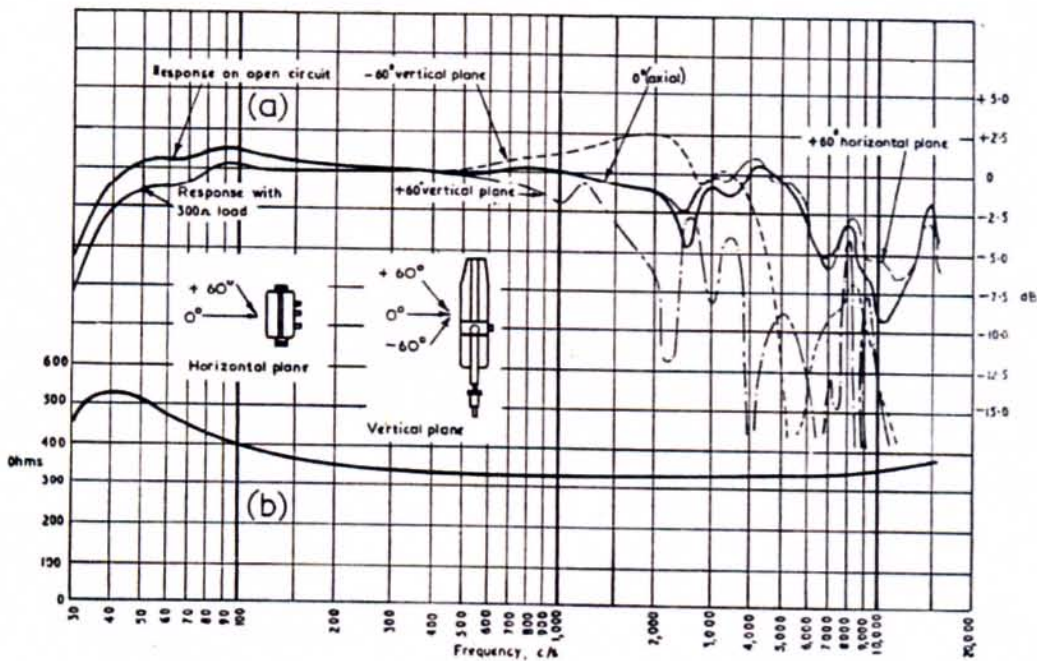

Fig. 21 — Microphone Type AXBT

- (a) Variation in response relative to mid-band value with angle of incidence and with electrical load
 (b) Modulus of output impedance

has a nominal impedance of 30 ohms. It will be noted that the alternative form of case construction used in the type PGD design has been adopted for the type 4038-A, the dished area extending to the upper end of the case. The output is connected to a three-pin plug at the base of the stem.

5. References

1. Megaw, E. C. S., Magnet Design for Large Air-gaps, J.I.E.E., Part IIIa, 93 (1946), pp. 939-48.
2. Kirke, H. L., Radio-Frequency Bridges, J.I.E.E., Vol. 92, Part I, January 1945, pp. 70-74.
3. Braunmühl, H. J. von, and Weber, W., Kapazitive Richtmikrophone, Hochfrequenztechnik u. Elektroakustik, Vol. 46, pp. 187-192, 1935.
4. Olson, H. F., Patent No. 2,348,356, 9 May 1944. Application date, 31 January 1941.
5. Olson, H. F., Patent No. 2,572,376, 23 October 1951. Application date, May 1948.
6. Shorter, D. E. L., and Harwood, H. D., BBC Patent Application 8315/53, 25 March 1953.
7. Shorter, D. E. L., and Harwood, H. D., BBC Patent Application 8316/53, 25 March 1953.
8. XV Plenary Assembly of the C.C.I.F., July 1949.
9. American Standards Association, Standard Z.24.3 - 1944, Sound Level meters for measurement of noise and other sounds.
10. Chinn, H. A., Gannett, D. K., and Morris, R. M., A new standard volume indicator and reference level. Proc. Inst. Radio Engineers, Vol. 28, pp. 1-17, 1940.
11. Foster, M. G., New BBC Microphones, Bulletin of the European Broadcasting Union, Vol. 4, No. 22, 15 November 1953.

ADDENDUM TO BBC ENGINEERING MONOGRAPH No. 1

We regret the omission of a reference to the Cinema-Television Ltd Patent Specification No. 638,443, in our Monograph entitled *The Suppressed Frame System of Telerecording*. The claims of this patent relate to apparatus for recording television images on film by recording part only of the signal and broadening the recorded lines to mask the missing signal portion.