

nonlinearcircuits

ARSeq Build & BOM vers1

The ARSeq (= Attack Release SEquencer) is, as the name implies a hybrid sequencer and AR envelope generator. It contains a counter circuit with reset, 4 envelope generators and a mixer/inverter stage to get the sequenced output. The envelopes can be inverted if desired to give a greater voltage and complexity range of the output sequence. The individual 4 envelopes are available on the panel as well.

The main difference with this circuit and a regular EG is each envelope requires 2 clock pulses, one to start the attack and the next to start the release stage.

clock 1	Attack stage Env 1, carry into Sustain stage if Att finished before clock 2 arrives
clock 2	Release stage Env 1
clock 3	Attack stage Env 2, output is mixed with the final parts of Env 1 if the release is set for a long fall. Carry into Sustain stage if Att finished before clock 3 arrives
clock 4	release stage Env 2
	and so on to 8 clock signals, then repeat!

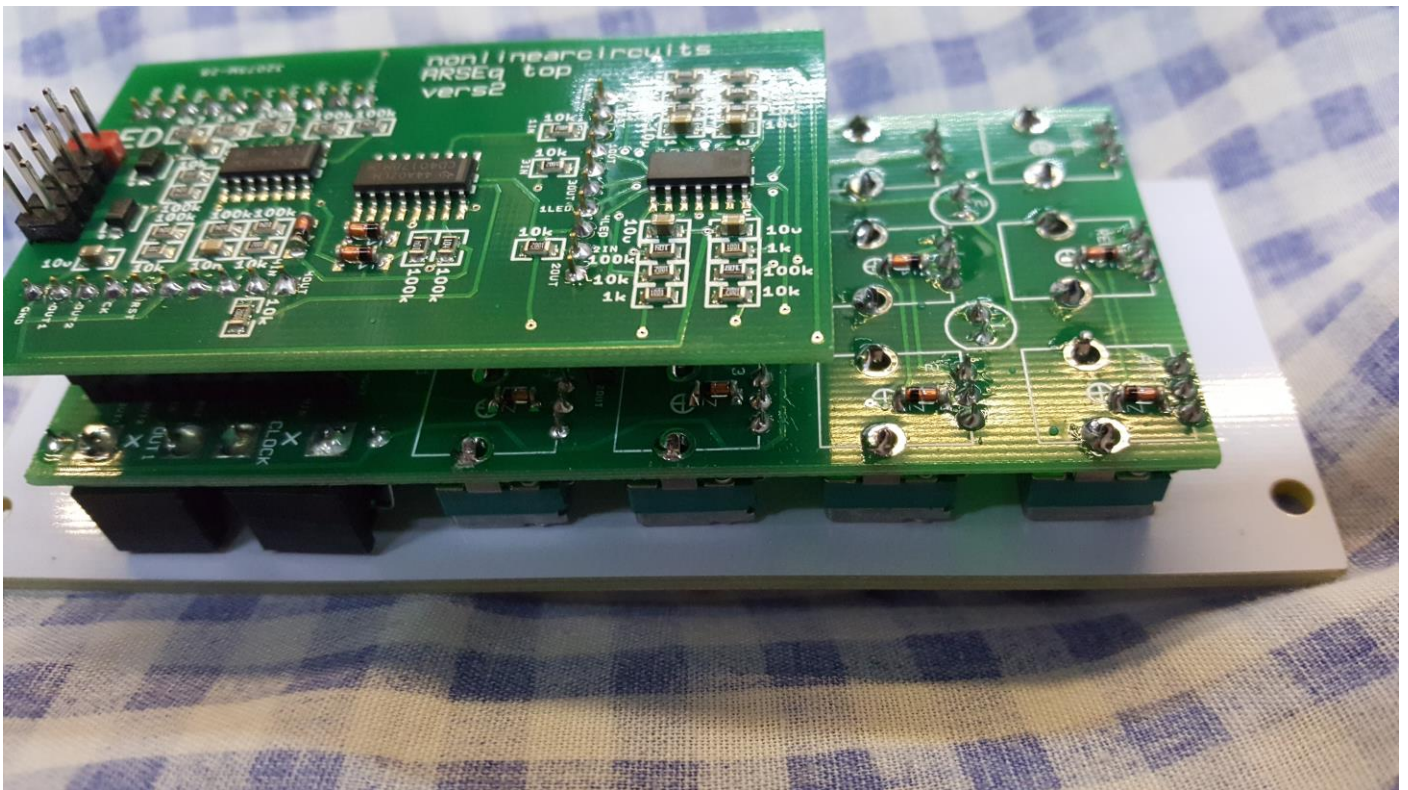

Building

For some reason I designed the panel to be quite narrow and the pots are fairly close together, too tight for Davies 1900H knobs. I suggest using spline shaft pots and obtaining some narrow width knobs, the kind I have on the Null-A. Befaco have some as do Aliexpress, Think might get some if you ask nicely☺.

There are a number of mods to be tried.

Longer envelopes – change the pots to 1M for longer attack & release times. I have noticed you can now get 22uF 25V 0805 caps so the 10uF caps could be changed as well for really slow envelopes. The caps to change will be indicated in the pic after the schematic. In my opinion, the best setup is 100k pots for Attack and 1M pots for Release.

Snappier envelopes – you will notice on the schematic the envelopes are charged by and drain thru the 4017 via 10k resistors. The 4017 pins are not really designed to drain much current so to keep the chip safe the 10k resistors are used. I was conservative choosing 10k (plus I like to design with 1k, 10k & 100k as much as possible), you could reduce these to get more snap in your envelopes but it might void your warranty on the 4017.

From the datasheet, the minimum current drain at 25C and 10V power supply is 1.3mA, typical is 2.6mA. On a 12V supply these values are a little higher but we don't want the chip operating near its limits, so sub in 12V instead of 10V. $12/1.3m = 9230$, so 10k is the next highest resistor and the one used in this circuit. 1.3mA is the worst case but within specs, typical is 2.6mA, so $12/2.6m = 4615$, next highest resistor is 4k7. So you could take a punt that your 4017 is 'typical' and replace the 10k resistors with 4k7, if the chip gets warm I suggest going back to 10k and accepting saggy envelopes are the kind you like best. After all that blather, *4k7 should be fine*, but anything less might give you grief.

LED brightness – The four 3mm LEDs should be super-brights, I use 10k resistors for these but if you need to adjust this value to save your eyes from getting lasered out, feel free to adjust this. The components are indicated in the pic after the schematic.

5mm LED – this can be a 2 pin bipolar if you wish as the output can go into negative voltages, or a regular LED. You may need to change the 4k7 current limiting resistor to suit your LED. Do not go lower than 4k7 to keep the op amp from being overworked as this can affect the main output.

<u>component</u>	<u>quantity</u>	<u>notes</u>
LL4148	11	Mouser: 512-LL4148
S1JL or similar	2	Mouser: 821-S1JL
panel pot 100k or 1M – see Building discussion	12	Tayda: A-1848 or find ones with splined shaft as suggested.
3.5mm jacks (Kobiconn style)	7	Tayda: A-865 or Modular Addict: PJ301M-12
3mm LEDs	4	superbright
5mm LED	1	can be 2 pin bipolar
10 Pin 2.54mm Single Row Pin Header Strip	3	Tayda: A-197
10 Pin 2.54mm Single Row Female Pin Header	3	Tayda: A-1306
Eurorack 10 pin power connector	1	Tayda: A-198
1k	5	0805
4k7	1	0805 (for 5mm LED, adjust if necessary)
10k	11	0805
100k	13	0805
10nF	1	0805, minimum 25V rating
10uF	6	0805, minimum 25V rating
TL074	2	SOIC
4017	1	SOIC, 4000 series CMOS

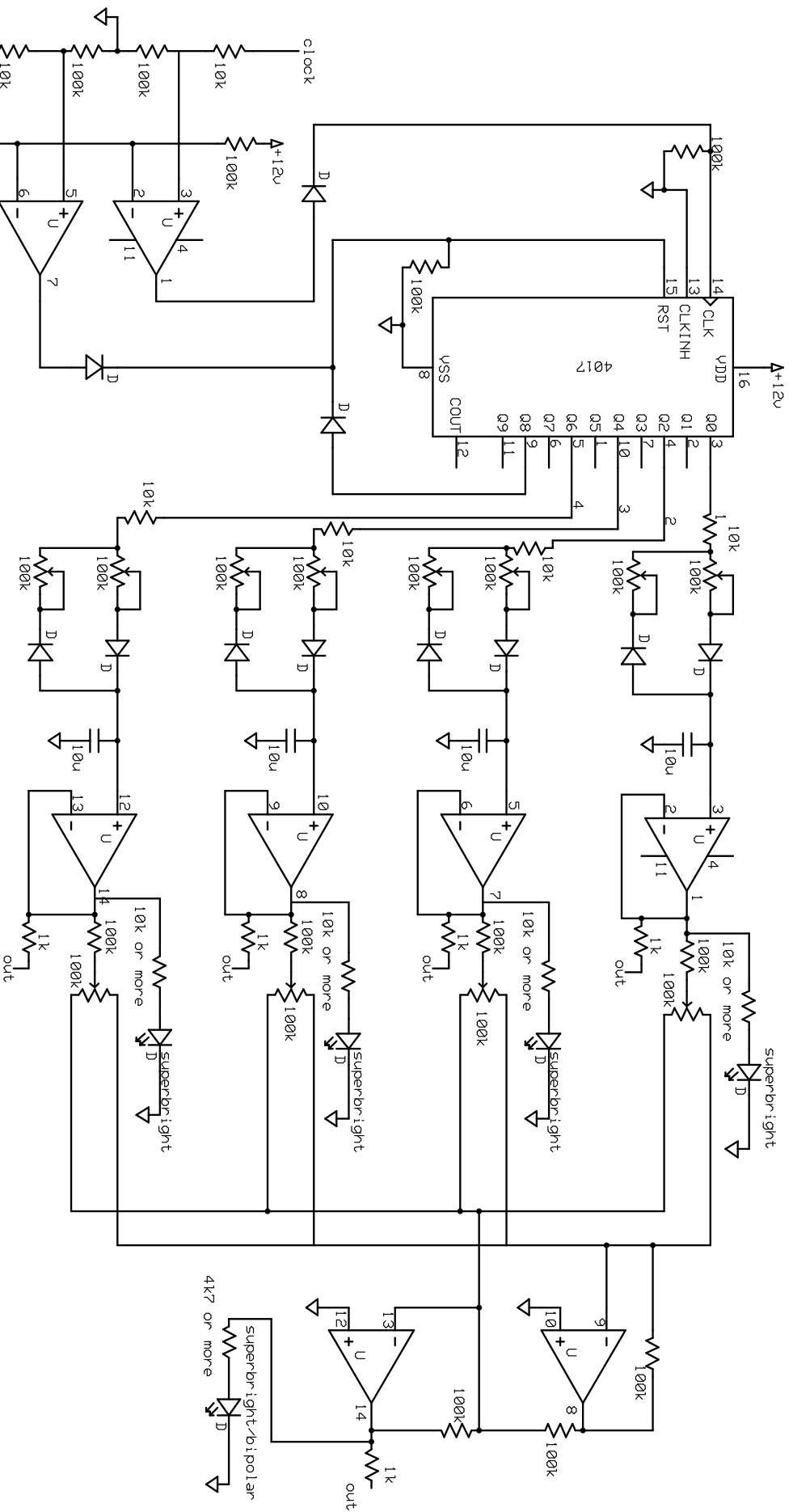

non linear circuits

ARseq

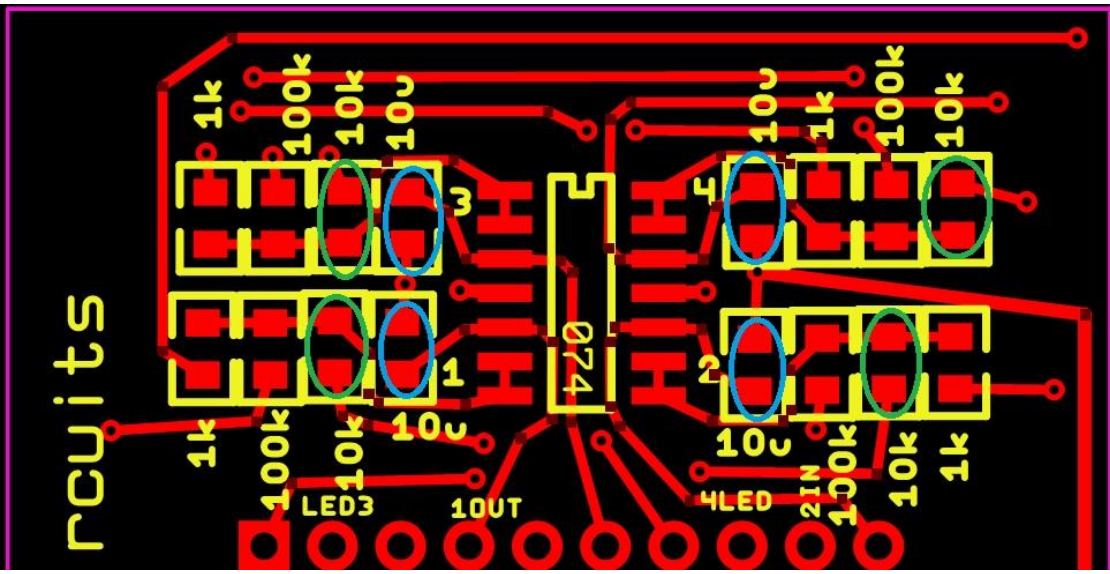

○ = change for longer or shorter envelopes

○ = current limiting resistors for 3mm LEDs

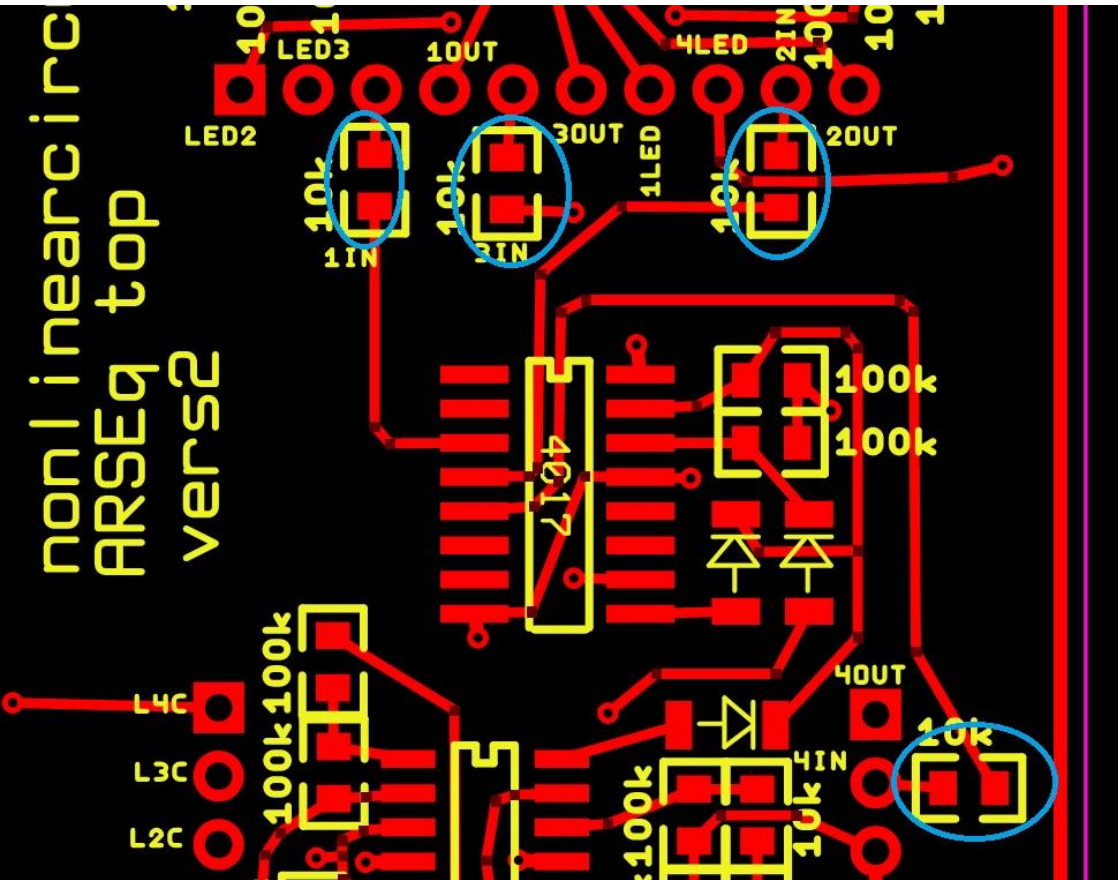

○ = change for snappier envelopes

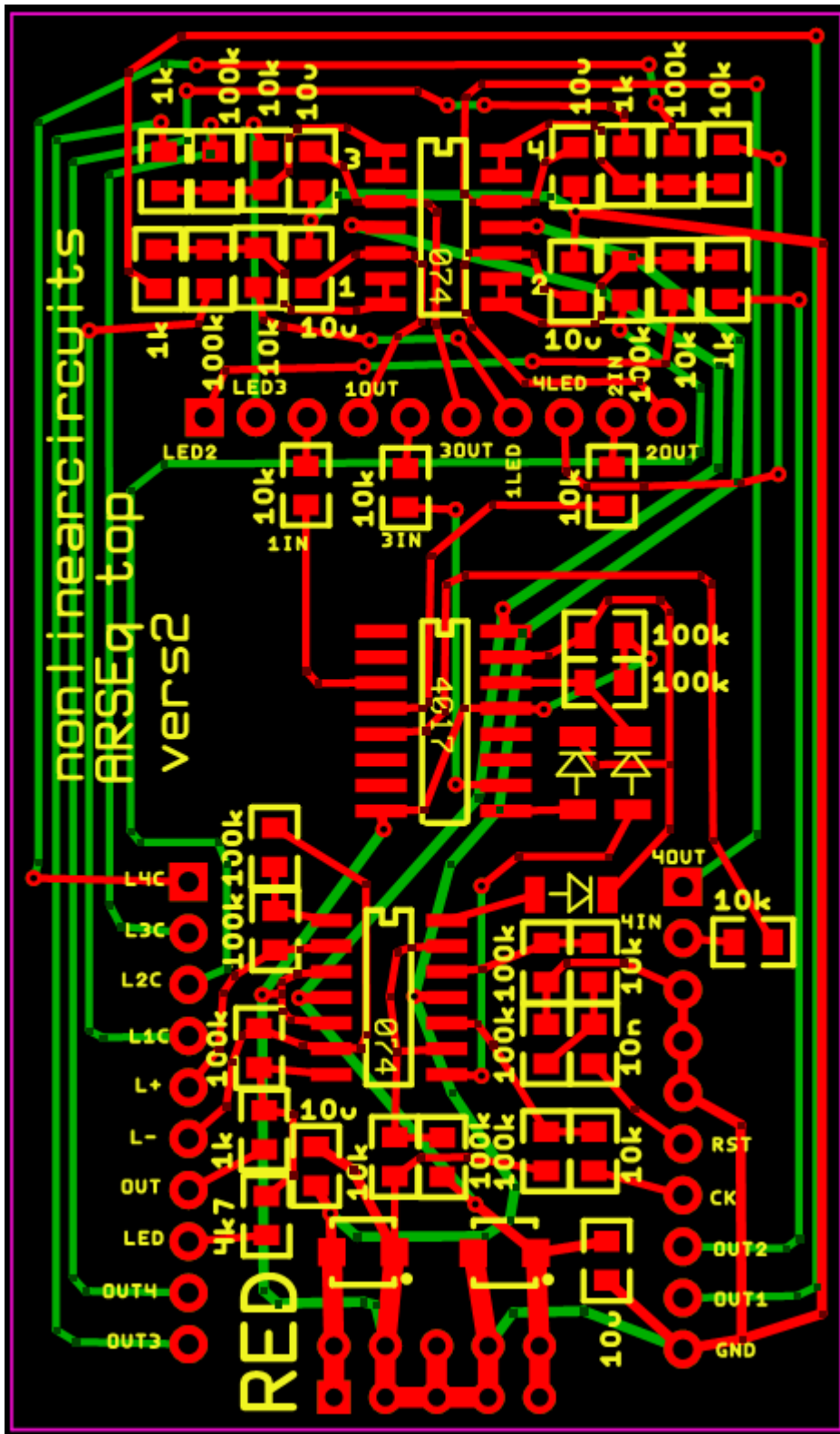

Top PCB

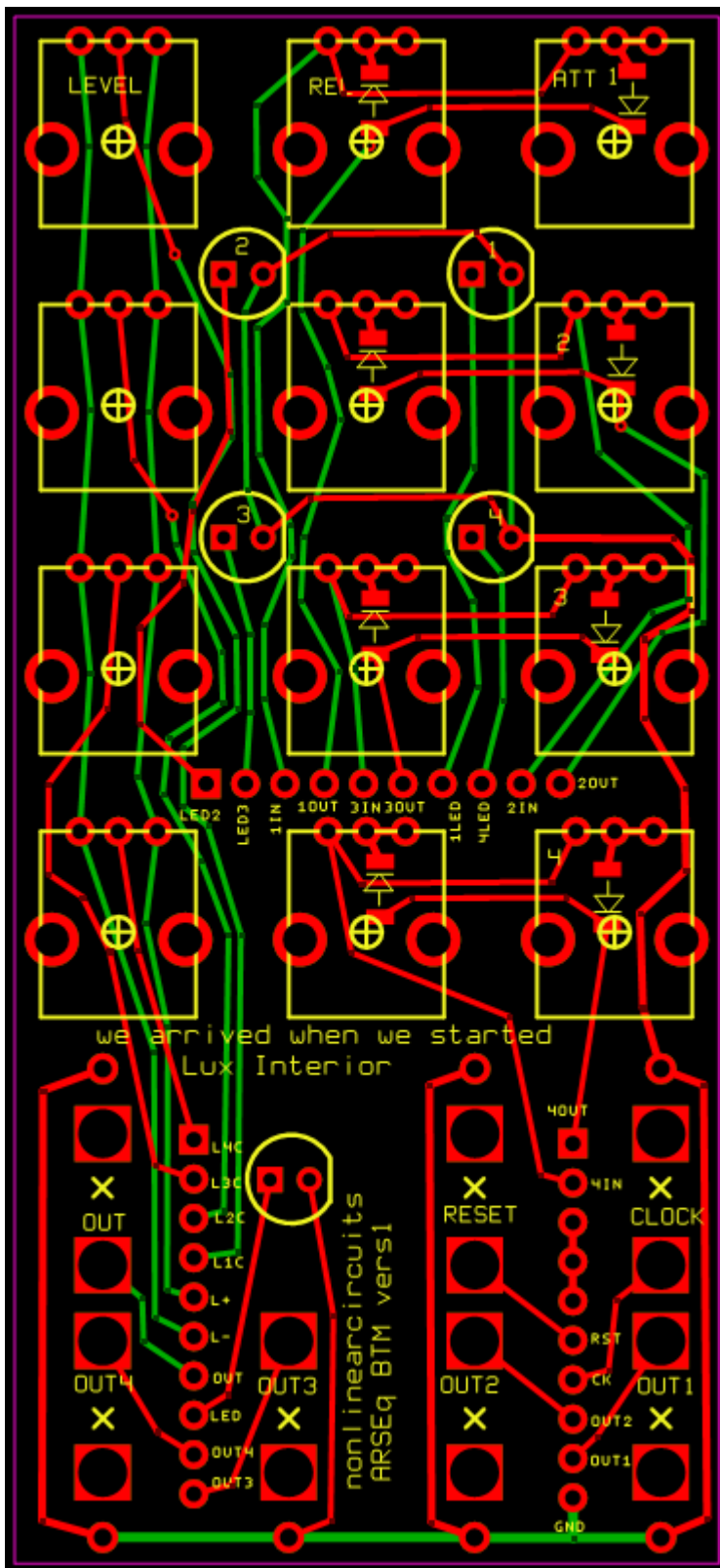

Regarding the Bottom PCB: 8 LL4148 diodes need to be installed, also note the pots, jacks and LEDs are mounted on the other side of the PCB to the diodes.