

nonlinearcircuits

BOOLS Build guide & BOM

vers1 (29/7/2015)

This is a multi-purpose module that can be used in a number of ways. It can be used for basic logic functions to generate complex gates. Using multiple inputs allows the creation of a variety of different but related gates which can be used to create complex but nicely sync'd patches. There is a R2R ladder to create a stepped CV signal that corresponds to the gate outputs, this is also fed thru a gate (or CV) controlled sample & hold/Slew circuit to create a smooth output.

Some tricks (depends on your choice of logic):

Use the module to process audio signals and feed the outputs back into other inputs.

The BOOLS can be used as an envelope generator. Choose an input to determine the height (1 = low, 4 = high), set the slope with the Slew pot, feed the S&H input with various signals to vary the envelope shape.

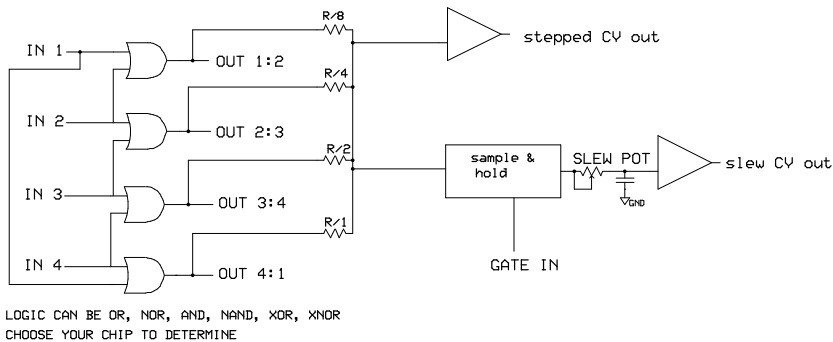

Suitable chips are

4001 NOR

4011 NAND

4071 OR

4081 AND

4077 XNOR

4030 or 4070 XOR

For me, the OR, XNOR & XOR chips are the most interesting. What makes this circuit a little different is the way the inputs and outputs are related.

There are four inputs, call them A, B, C & D, say we have an XOR chip installed and signals on all four inputs

Output 1 will be A xor B

Output 2 will be B xor C



Output 3 will be C xor D

Output 4 will be D xor A

The input signals can be pretty much anything that crosses 1.1V. Outputs will be 5V.

Audio rate signals are fine; XOR chips give a crude but useful ring modulation effect.

BOM

component	quantity	remarks
4001/4011/4030/4070/4071/4077/4081	1	DIP CMOS to suit the logic function you want
TL074	1	DIP
TL072	1	DIP
BC547	5	NPN thru-hole
J112 or J108 FET	1	thru-hole
1N4148	5	thru-hole
LED	4	NOTE: 3mm size for NLC panel
jacks	11	 Kobiconn style
1M pot	1	 see notes
100nF capacitor (or larger) ('104' on PCB)	2	1206 or 0805, for decoupling (on bottom of PCB)
1uF capacitor	1	1206 or 0805 – see notes
10uF electro	2	thru-hole, minimum 25V rating, 2mm lead spacing
10R	2	thru-hole
1k	11	1206 or 0805
10k	7	1206 or 0805 (one is on the bottom)
100k	15	1206 or 0805
200k	6	1206 or 0805
RL (LED resistor)	4	1206 or 0805, select value to suit LED brightness
14 pin IC socket	2	
8 pin IC socket	1	
eurorack power connector (10 pins)	1	

NOTES:

The pot and the 1uF capacitor combine to create and control the slew rate in the smooth CV output. You can try other combinations such as 10uF and 100k pot or for very slow 10uF and 1M pot. 47uF was too much but 22uF was okay if you like it really slow and goey.

Building

1. It is best to install the 1206 or 0805 components on the back of the PCB first, and then install the 1206 or 0805 components on the top of the PCB. After this install the sockets, power pins and thru-hole components.
2. Connect the pots and LEDs to the back of the PCB, but do not solder them.
3. Regarding the LEDs; the long lead goes into the round hole, short lead in the square hole.
4. Attach the jacks to the panel, so the ground tabs are oriented correctly.
5. Mate the panel to the PCB, ensure everything lines up properly, place the nuts on the pots, and then solder everything on.
6. Use some wire clippings to connect the jack ground tabs to the PCB.

For the LEDs, you need to choose the value of the current limiting resistors so your LEDs are at the desired brightness; these are all marked as RL on the PCB. If using the NLC PCB, please note that the LEDs are 3mm rather than the regular 5mm size.

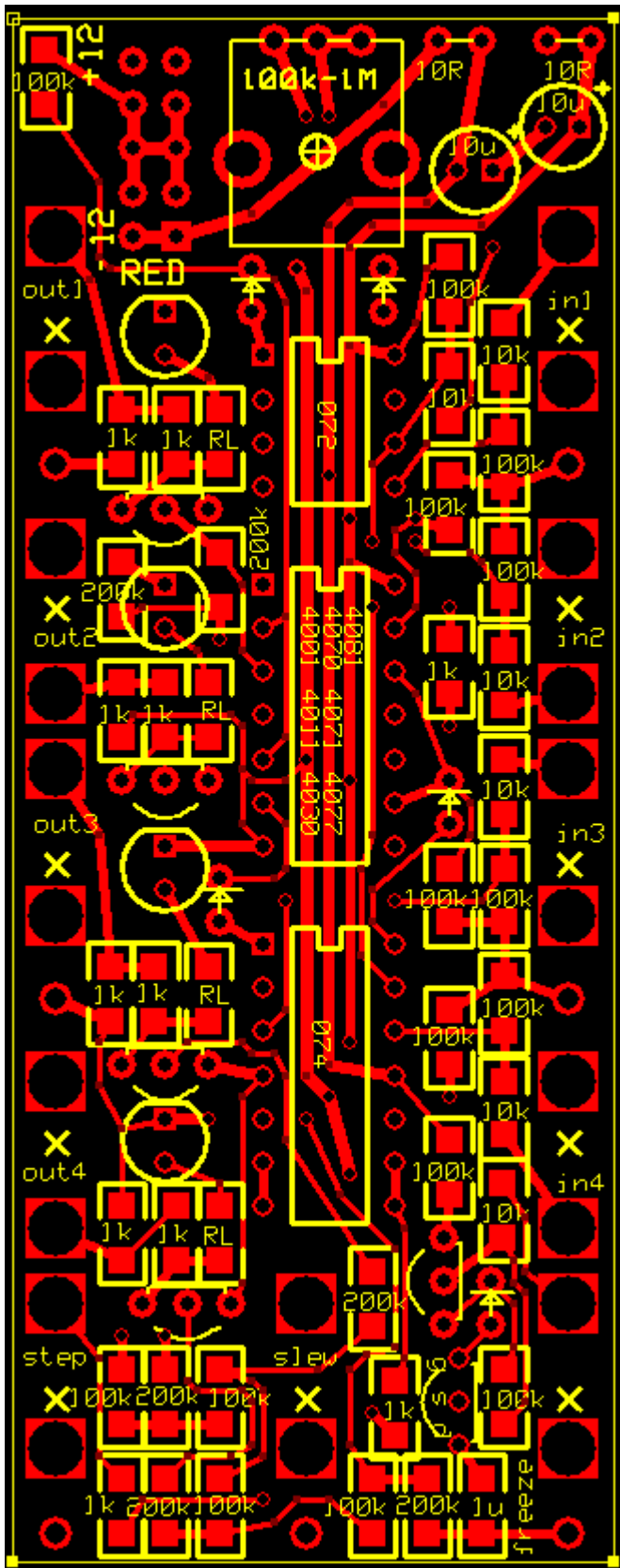

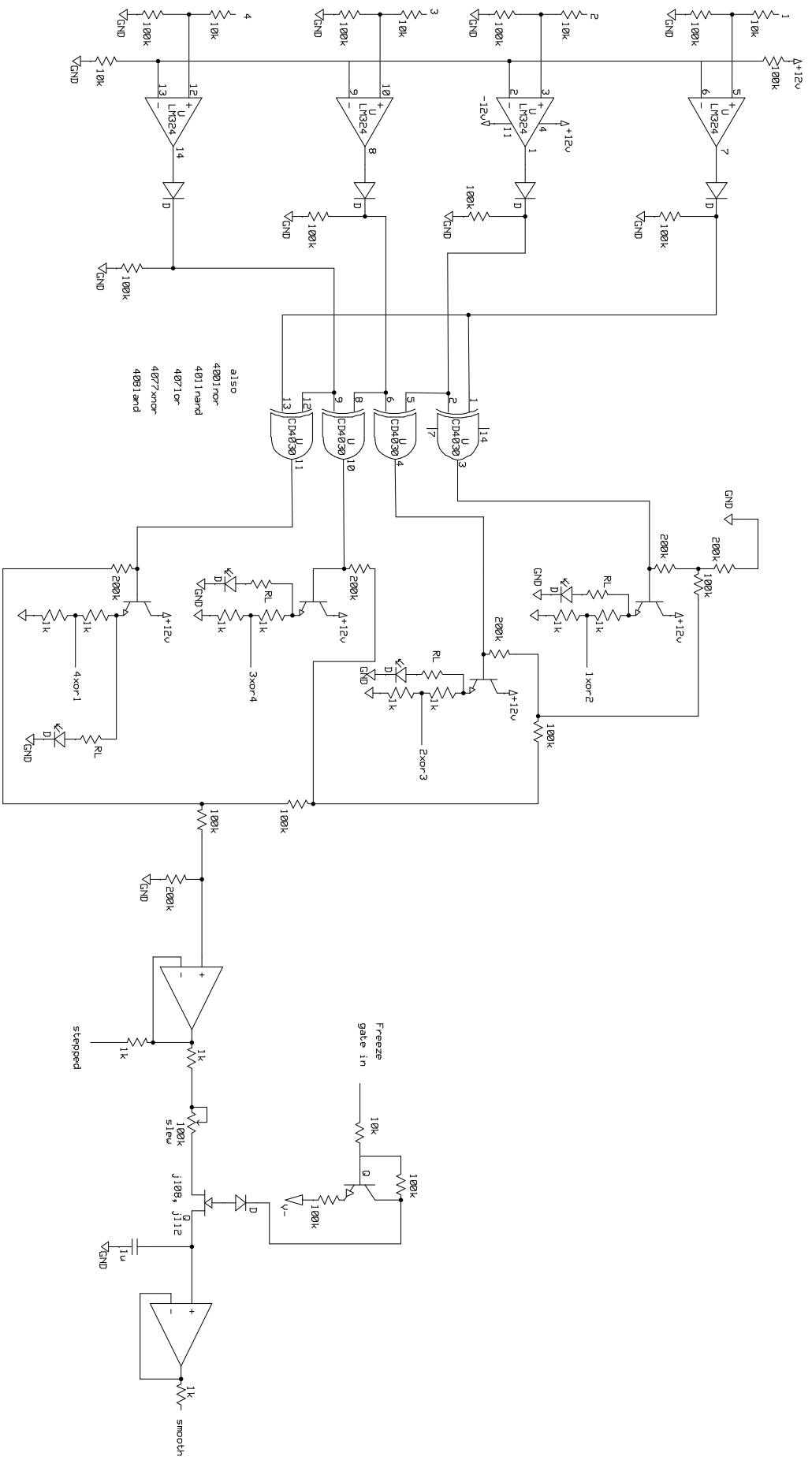

nonlinearcircuits

bool