

NONLINEAR CIRCUITS: SLOTH CHAOS

updated - 7Dec2016

You can build 4 different types on one PCB, choose your flavour. Regular sloth takes 15-20 seconds to complete a double well/figure 8/butterfly wings....if that is what it chooses to do. Apathy takes about 1 minute, Super sloth takes 15-20 minutes and Stasis Sloth takes about 1.5 hours.....it is seriously fkn slow. All Sloths can get stuck in a well for several revolutions, this means the LED does not always change colour very often. In the regular Sloth this means the LED may not change colour for up to 5 minutes, though it usually does 2-3 times a minute. For the Stasis Sloth the LED may not change for a few days.....

COMPONENT	SLOTH	Apathy (1 min)	Super SLOTH	Stasis SLOTH
R1	100k	1M	1M	750k
R2	100k	100k	680k	680k
R3	1k	1k	1k	1k
R4	1k	4k7	4k7	4k7
R5	100k	100k	910k	910k
R6	1M	6M8	6M8	6M8
R7	4M7	10M + 4M7 =14M7 (solder 2 resistors together in series)	10M	10M
R8	RL – suit LED (330R – 10k)	RL – suit LED (330R – 10k)	RL – suit LED (330R-10k)	RL – suit LED (330R-10k)
R9	100k	1M	1M	680k
R10	91k	1M	820k	680k
R11	10R	10R	10R	10R
R12	10R	10R	10R	10R
R13	-	4k7 – <i>see notes</i>	4k7 – <i>see notes</i>	4k7 – <i>see notes</i>
C1	100uF	100uF	1000uF	4700uF
C2	100uF	100uF	1000uF	4700uF
C3	1uF (mcc or BP/NP electro)	1uF (mcc or BP/NP electro)	10uF BP (non- polarized)	47uF BP or NP
C4	1uF (mcc or BP/NP electro)	1uF (mcc or BP/NP electro)	10uF BP	47uF BP or NP
C5	1uF (mcc or BP/NP electro)	1uF (mcc or BP/NP electro)	10uf BP	47uF BP or NP
C6	10uF	10uF	10uF	10uF
C7	10uF	10uF	10uF	10uF
IC	TL074	TL074	TL074	
LED	must be 2 pin bipolar	must be 2 pin bipolar	must be 2 pin bipolar	
P1	10kB	100kB	250kB	100kB – 250kB

The LED must be a two pin bipolar type to show positive and negative going voltages, the LED is simply one colour when the output is positive and changes to the other colour when the signal goes below 0V. In **Super Sloth**, it may stay one colour for a very long time, but usually a cycle crosses zero at some point.

Sockets should be Kobiconn or similar (the ones from Tayda are ok)

For **Super Sloth and Stasis Sloth** versions, C3-5 must be bipolar/non-polarized capacitors, you can find them easily on ebay. For **Sloth**, these can be regular MCC 1uF (not electrolytic)(4.5mm spacing).

C1-5 have extra holes for mounting larger or smaller capacitors.

In **Sloth** version, one cycle takes approx. 15 seconds. In **Super Sloth**, one cycle takes approx. 15 minutes.

The pot does alter frequency a little, perhaps from 12-16 seconds in **Sloth** and 12-16 minutes in **Super Sloth**. It also alters the patterns, at some settings there will be little activity, sometimes for a few minutes.

For **Stasis Sloth**, the 4700uF caps may be a bit large for the PCB. The leads are strong enough to stand them 1cm up off the board; you could also mount C3 & C4 underneath the PCB and bent over to be horizontal, if you really need the space.

Also for **Stasis Sloth only**, R13 reduces the 'big' or 'Y' output to a manageable size (approx. +/-5V). There is no marking for it on the PCB, it must be soldered onto the socket as shown in the pic below. Do this last!

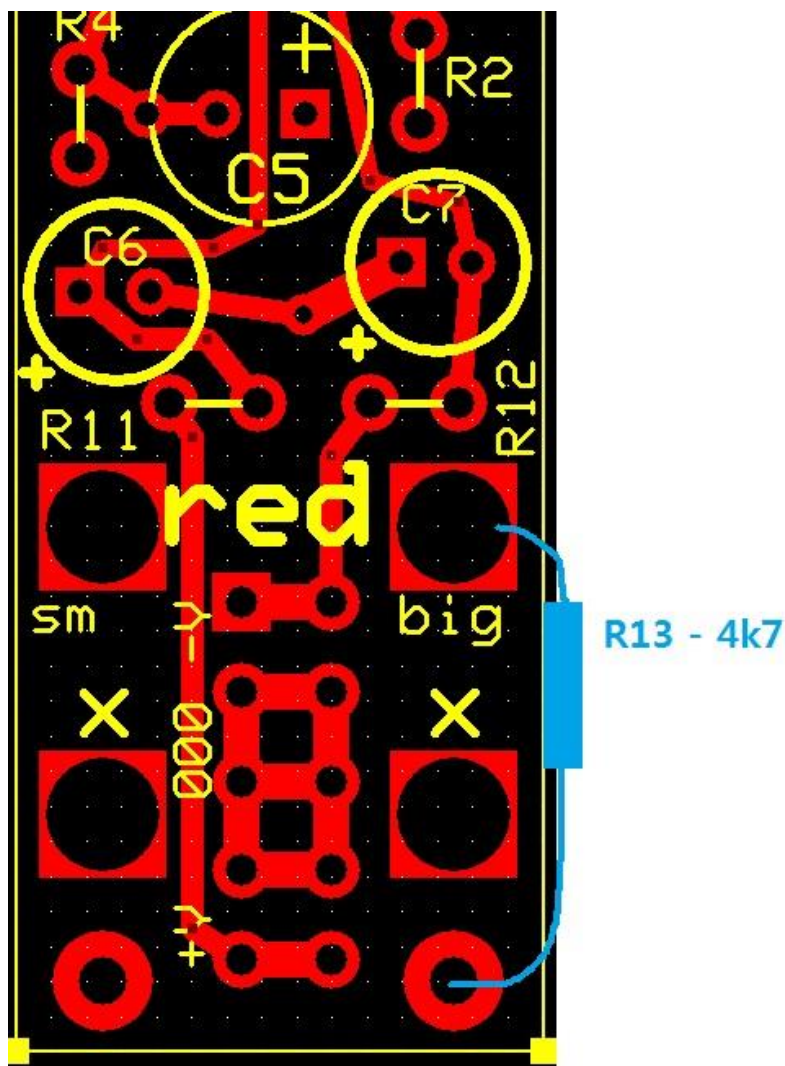

Stasis Sloth ONLY

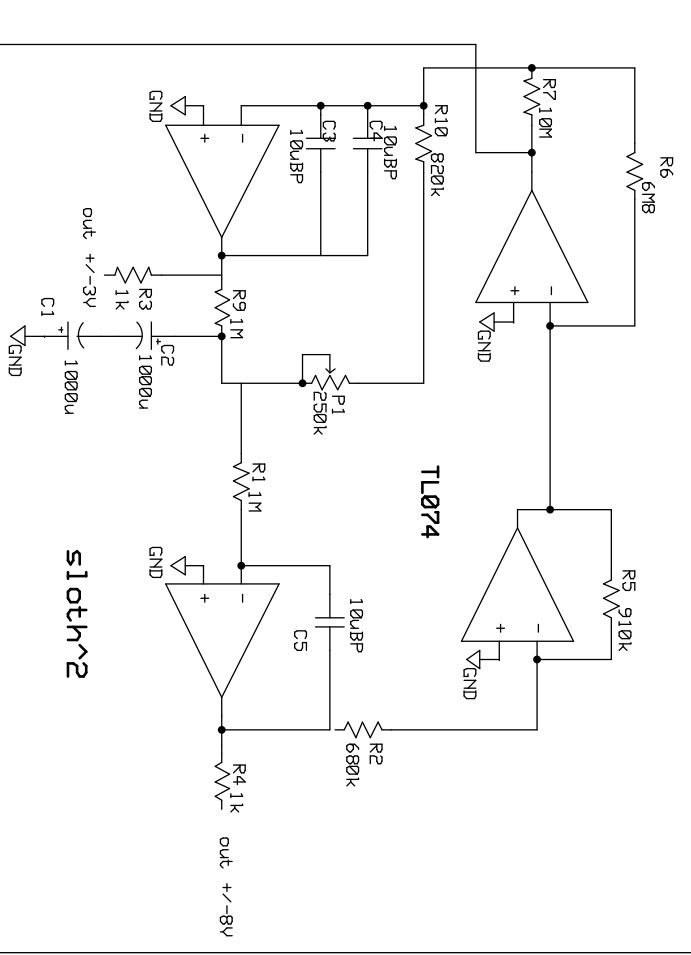
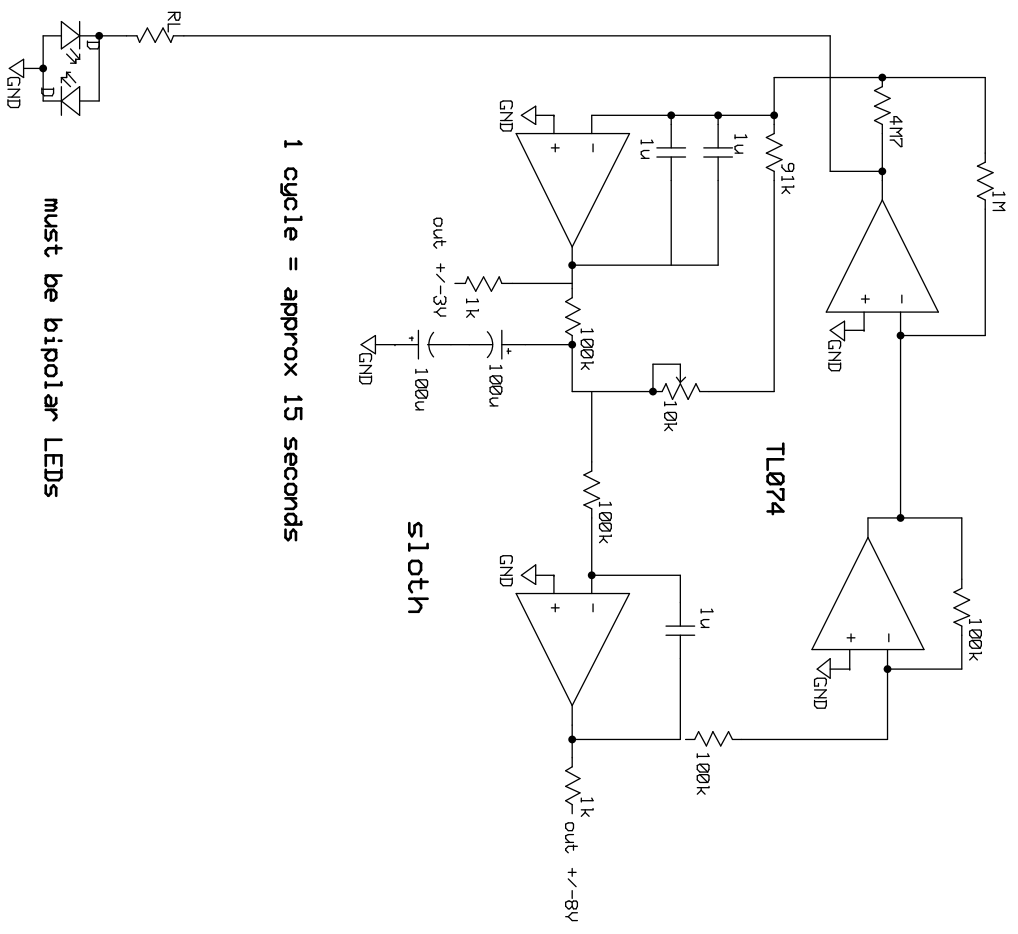

nonlinearcircuits

sloth & sloth^2